



Geprüfte Personenerdung durch das 3M724 Constant Monitoring System

Durch häufig wechselndes Personal oder lange Schulungsintervalle kann es passieren, dass Kenntnisse zum ESD-Schutz verloren gehen. Dies kann zu Qualitätsproblemen führen.

Eine durchgängige Prüfung des ESD-geschützten Arbeitsplatzes deckt schonungslos Sicherheitslücken in Ihrem ESD-Schutzkonzept auf und kann helfen, ESD-Schäden zu reduzieren.

Am Markt existieren verschiedene Ansätze, eine permanente Überwachung zu realisieren. Seit Jahren bewährt ist das 3M724 Constant Monitoring System. Im Gegensatz zu anderen Systemen wird nicht nur kontrolliert, ob ein Objekt am Handgelenkband hängt, welches annähernd die Kapazität eines Menschen hat. Bei 3M wird über einen echten Messkreis alle 2 Sekunden geprüft!

Dabei schließt die 3M Doppelleiter-Konstruktion den Hautwiderstand der Person in einen Messkreis ein. Dadurch wird gleichzeitig abgesichert, ob die Person das Handgelenksband korrekt angeschlossen hat und alle Teile voll funktionstüchtig sind. Fehlerquellen wie zu lockeres Tragen oder Anlegen über dem Ärmel der Privatkleidung sind automatisch ausgeschlossen. Unter anderem wurde bei einem Kunden festgestellt, dass eine Mitarbeiterin eine zu trockene Haut für die Erdung über das Handgelenk hatte (hier konnte mit einer ESD-Lotion Abhilfe geschaffen werden).

Prinzipiell ist die Erdung über das System Handgelenksband und Spiralkabel noch immer die zuverlässigste Erdung überhaupt. Mit keiner anderen Maßnahme können Sie ein niedrigeres elektrostatisches Potenzial bei einer Person erreichen. Gerade für Endprodukte, welche in High-Tech-Anwendungen eingesetzt werden, ist es wichtig jederzeit zu wissen und nicht nur zu vermuten, dass die ESD-Schutzmaßnahmen funktionieren.

Was passiert, wenn bei der täglichen Prüfung der Handgelenkserdung an einem „zentralen“ Prüfgerät festgestellt wird, dass ein Spiralkabel defekt ist? Üblicherweise sollte der Mitarbeiter ein neues Spiralkabel erhalten. Ist damit der Fall erledigt? Wissen Sie, wann der Defekt aufgetreten ist? Wissen Sie, wie viele Produkte der Mitarbeiter zwischen dem Auftreten des Defekts und der Erkennung bearbeitet hat? Und wissen Sie, ob in diesen Produkten nun latente Fehler vorhanden sind?

Das 3M724 Constant Monitoring System gibt Ihnen nicht nur diese Gewissheit, es prüft zusätzlich die komplette Erdung des Arbeitstisches mit. Demnach entfällt zusätzlich zu den täglichen Prüfungen der Bänder und Kabel auch die durch die ESD-Norm vorgeschriebene tägliche Sichtkontrolle der Arbeitsplätze durch Ihren ESD-Koordinator.

Befreien Sie sich von hohem Aufwand, unnötiger Bürokratie und geben Sie Ihren Produkten die notwendige ESD-Sicherheit.

Schematische Darstellung eines durch einen 3M 724 Constant Monitor überwachten Arbeitsplatzes:

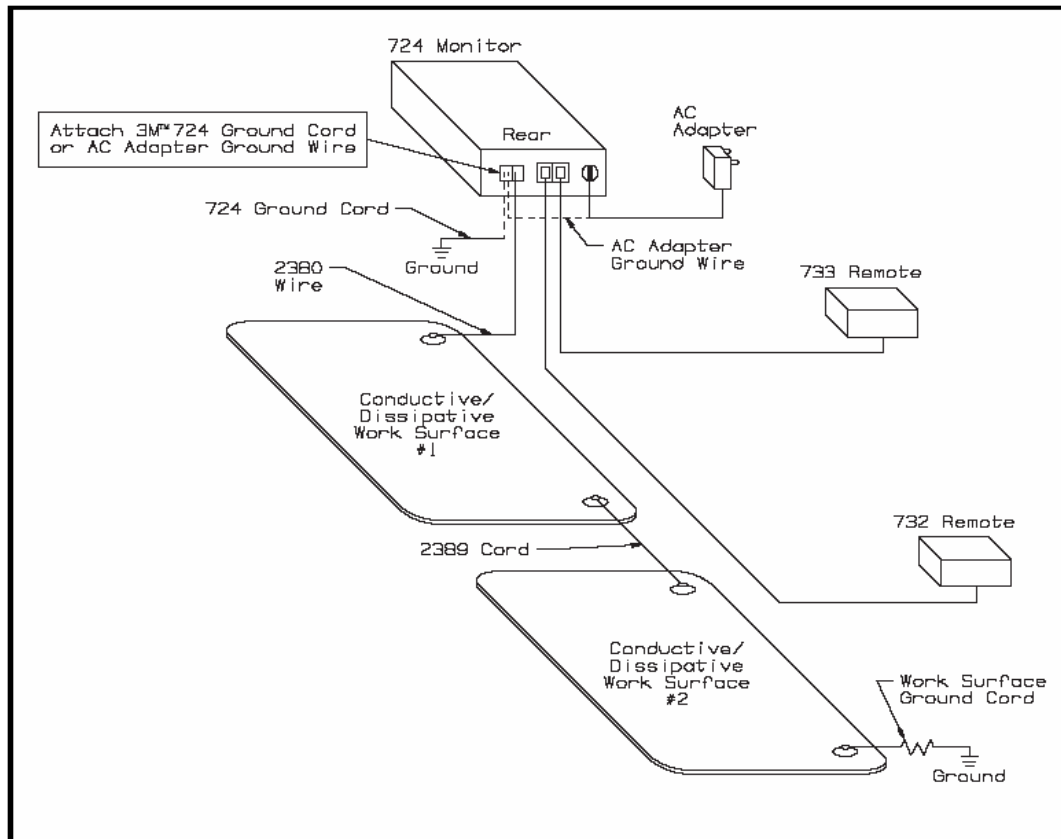

Fig. 17 - Model 724 wire connection diagram for two work stations.

Benötigt wird:

1 Set 3M 724 mit folgendem Lieferumfang:

1 x Model 724 Work Station Monitor, 1 x Model 732 Dual Conductor Remote Input Jack, 1 x AC Adapter (North America Only), 1 x 724 Ground Cord, 1 x 2380 Monitor/Table Mat Cord, 1 x Zwei-Kabel Anschluss, 4 x Schrauben, 2 x Wire Management Clips, 1 x User Instruction Manual

1 St. Netzteil 3M oder gleichwertig für Europa 25Vdc@50mA

je mindestens ein Handgelenksband und Spiralkabel „Dual Conductor“

Für den Anschluss eines zweiten Arbeitsplatzes wird ein Kabel 3M2389 benötigt, außerdem eine weitere Anschlussbox 3M733 (mit dem Lieferumfang Erdungsbox und 1,8m Kabel). Ein „Stand-By Jack“ 3M3057 wird nur benötigt, wenn zwei Mitarbeiter an einen Monitor angeschlossen sind. Dann kann der Stecker den Sensor überbrücken, falls einer der angeschlossenen Mitarbeiter den Platz verlässt, während der zweite weiterhin angeschlossen bleibt.

Die Kalibriereinheit ist nur notwendig, sofern die Prüfung intern stattfinden soll.

Für weitere Fragen stehen wir gern zur Verfügung.

3M

Model 724 Work Station Monitor Instructions



Index

Section	Page
Safety Information.....	3
1. Theory of Operation.....	4
2. Installation of 3M™ Model 724 Monitor with Work Surface Ground Monitoring.....	8
3. Installation of Model 724 Monitor without Work Surface Ground Monitoring	9
4. Selection of Test Voltage and Resistance Limit	12
5. Mounting the 724 Monitor and 3M™ Model 732 Remote.....	12
6. Wrist Strap Connection	13
7. Fault Conditions	14
8. 3M™ Model 3057 Standby Jack.....	15
9. 3M™ Model 733 Dual Conductor Remote Input Jack	15
10. Installation of Model 733 Remote.....	15
11. Verification Procedure for the Model 724 Monitor.....	16
12. Specifications	19
13. Parts Included.....	19
14. Required Accessories and Optional Available Parts.....	20
15. Additional Wrist Strap Monitoring Information	20
16. Warranty	21

Safety Information

Intended Use







The 3M™ Model 724 Work Station Monitor is designed to monitor the operation of two wrist strap grounding systems and two work surfaces. This product has been designed and tested for use with 3M™ Dual Conductor Wrist Straps and 3M Work Surfaces Grounding Systems. For North America this unit is designed for use with an AC adapter included. Outside North

America, obtain an appropriate AC adapter meeting the specifications as stated in the user instruction manual (Section 12). Use of other components may cause improper performances and/or unsafe conditions. For use outside of North America, grounding of the Model 724 Monitor is recommended through a separate ground wire with ring terminal supplied (Sections 2 and 3).

CAUTION

- Incorrect grounding of an operator may cause electrostatic discharge (ESD) damage to components or assemblies being handled. For proper grounding of the operator when using the 3M 724 Work Station Monitor, use of the three-prong AC adapter specified in the user instruction manual or supplied ground wire with ring terminal is required.
- Verify that the electrical ground point is suitable. If you are not sure what a suitable ground is, contact a licensed electrician before installation.

Explanation of Symbols

-  – Caution: refer to user instruction manual.
-  – Operator(s) Wrist Strap Assembly Ground.
-  – Work Surface Ground.
-  – Electrical ground.
-  – Power input connector polarity (center negative).
-  – See user instruction manual for explanation of the indicator lamps.

Read and understand all safety information before operating this equipment.

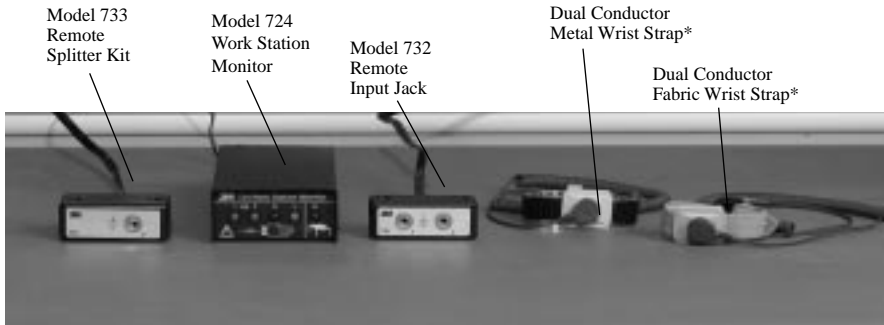

Fig. 1 - Model 724 Work Station with dual conductor wrist strap assemblies and remote input jacks.

Section 1. Theory of Operation

The 3M Model 724 Work Station Monitor (Fig. 1) is designed to monitor the operation of the wrist strap grounding systems of two operators. To accomplish this, it uses a DC current source to measure a loop electrical resistance. The system uses a special wrist band and ground cord that contain two independent elements.* The 724 monitor employs two selectable test voltages (9 and 16 volts) and resistance limits (10 Megohms and 35 Megohms).** It also monitors the grounding of up to two 3M work surfaces.

The Model 724 monitor performs a resistance measurement by applying an electrical current of less than $3 \mu\text{A}$ approximately every 2.0 seconds for 0.2 of a second in duration. The path for the current is through one conductor of the ground cord that

contains a current-limiting resistor, through one side of the wrist band, through the skin of the wearer under the band, through the second side of the wrist band, through the second conductor of the ground cord that contains a current-limiting resistor, and finally back to the monitor.

Selection of Test Voltage and Resistance Limit



Fig. 2 - Resistance/Voltage switch selection.

*Resistance values are $\pm 15\%$

The Model 724 monitor allows for the selection of test voltages (9v or 16v) and resistance limits (10 Megohms or 35 Megohms). The additional ranges have been added to accommodate global Electrical Static Discharge requirements. Selection of the operating parameters are left up to the user's discretion (See Section 4).

Operator Monitoring - Single and Dual

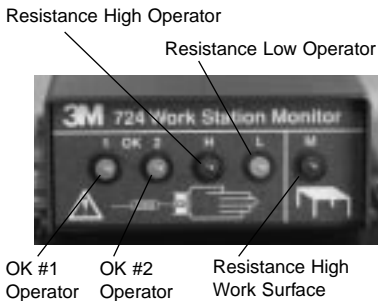

Fig. 3 - Face of Model 724

The wrist strap monitoring function is activated by plugging a wrist strap dual conductor ground cord into either one of the jacks on the 3M™ Models 732/733 Dual Conductor Remote Input Jack. If the resistance of the wrist strap loop is within the limits of the selected range (1.5 Megohms to 10 Megohms or 1.5 Megohms to 35 Megohms)* on the Model 724 Monitor, the cord, the wrist band, and the contact to the arm of the wearer, it is considered to be functioning correctly. At this time, one of the (OK) green lamps (1 or 2) will be illuminated on the front of the monitor.

If the resistance of the wrist strap loop is higher than the selected range (10 Megohms or 35 Megohms)* on the 724 monitor, an (OK) wrist strap green lamp (1 or 2) extinguishes, and a high wrist strap red lamp (H) illuminates with an audible alarm. This is an indication of a high resistance in the cord band, or poor contact between arm and band. If the resistance in the loop is under 1.5 Megohms,* it is an indication of a low resistance meaning one or both current-limiting resistors are bypassed. The low yellow lamp (L) will flash and an (OK) green lamp (1 or 2) will remain illuminated.

⚠ Caution
A low resistance condition can also be caused by touching a grounded object or by standing on a conductive surface.

The wrist strap of a second operator is measured in the same way. Operators are identified by the two (OK) green lamps (1 & 2). However, the same high wrist strap red lamp (H) and low yellow (L) lamps illuminate when a fault is detected. The green lamp that extinguishes identifies the operator that is experiencing the fault condition.

* Resistance values are ±15%

3M 733 Remote Splitter Kit purchased separately.

Voltage on Operator When Connected to the Model 724 Monitor

There is a concern about the voltage that is applied to an operator while they are connected to a monitor. Some of today's electronic components are extremely sensitive to electrostatic discharge from a person (less than 10 volts). The following chart for

the Model 724 monitor illustrates the level of voltage that will appear on the operator under various resistance conditions.

Note:

For more information about wrist strap monitoring see Additional Wrist Strap Monitoring Information (Section 15).

Voltage on Operator when connected to the Model 724 monitor

Condition	9V-10 Megohms	9V-35 Megohms	16V-10 Megohms	16V-35 Megohms
No Skin Resistance	0.9V	0.9V	1.6V	1.6V
200K Ohm Skin Resistance	1.0V	1.0V	1.8V	1.8V
Likely Case Before Alarm	2.5V	3.6V	4.4V	6.4V
Worst Case Before Alarm	4.5V	7.1V	8.0V	12.6V
Absolute Worst Case	9.0V	9.0V	16.0V	16.0V

Audible Alarm Tones

For wrist strap malfunctions the Model 724 monitor indicates a different tone for each operator—a continuous tone for #1 operator and a fast chirping beep for #2 operator. The volume of the wrist strap alarm is adjusted by selection of the internal DIP switch #1. For work surface malfunctions, a slow chirping beep is made. This alarm sound is turned on or off by selection of DIP switch #2. Switch #1 and #2 are accessible through a slot located in the bottom of the chassis.

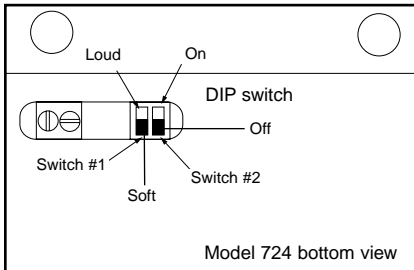

Fig. 4 - Selected desired alarm options

Work Surface Monitoring

The Model 724 monitors its connection to ground and the grounding of a 3M ESD work surface. A loop resistance is measured from the monitor, through a 3M™ 2380 Monitor/Table Mat Cord to the work surface (Section 2), across the conductive layer of the work surface, through the grounding wire of the work surface to an electrical ground

and finally back to the monitor through the 724 grounding wire. If the resistance of the loop exceeds 3.7 Megohms* the work surface high red lamp (M) will illuminate and all green lamps will be extinguished. If DIP switch #2 is in the ON position (Fig. 4) the audible alarm will activate. If no ESD work surface is to be monitored, the 3M 2380 Monitor/Table Mat Cord and the ground wire of the 724 must be connected to an electrical ground (Section 3). This is done to ensure that the 724 is providing a ground connection for the operators. Again, if the loop resistance exceeds 3.7 Megohms the work surface high red lamp (M) will illuminate and the alarm will activate if selected.

⚠ Caution

The grounding wire from the work surface and the ground wire from the Model 724 monitor must be attached to separate electrical grounds. The work surface monitoring function is active any time that the power supply for the monitor is plugged in.

⚠ Caution

Disconnect the 3M 2380 Monitor/Table Mat Cord to prevent possible damage to the Model 724 monitor before testing the resistance of the work surface with a high voltage megohmmeter.

* Resistance values are $\pm 15\%$

Section 2.

Installation of 3M™ 724 Monitor with Work Surface Ground Monitoring

Wire Attachments and Grounding - See Fig. 12 for complete drawing of the Model 724 monitor wire connections.

Tools required - Small blade, screwdriver and wire cutter.

Note:

Two snap fasteners or appropriate connectors must be installed at opposite corners of the work surface to use this feature. Recommended surfaces are 3M™ 8200, 8300, and 8800. Use of a 3M™ Female Snap Fastener 3034 or 3050 (depending on the type of surface) is recommended for connection to the 3M™ 2380 Monitor/Table Mat Cord that is supplied with the Model 724 monitor. If you are using the 3M 8300 Dissipative Hard Laminate Material, attach the 3M™ 2380 cord to suitable hardware used to make an electrical connection to the ground layer of the work surface. This may require you to cut off the plastic cap end of the 2380 cord.

a) Connect the work surface to an electrical ground with the appropriate one megohm ground cord you received at time of purchase.

- b) Using a small screwdriver move the DIP switch #2 on the Model 724 monitor to the ON position to activate the work surface audible alarm (Fig. 4).
- c) Locate the accessory package that contains a 3M™ 2380 Monitor/Table Mat Cord, Model 724 ground wire (with ring terminal), and the two-wire connector plug.
- d) Attach the 3M 2380 (tinned wire end) to the work surface terminal of the two-wire connector by inserting it into opening and securing with the screwdriver (Fig. 5A or 5B). Attach the plastic cap end to the snap on the work surface.

Note:

If for any reason a snap fastener cannot be used on the work surface, the plastic cap on the end of the 2380 cord can be cut off and replaced with a ring terminal not supplied (Fig. 6).

- e) Determine how you want to ground the Model 724 monitor:
- If you are grounding through the AC adapter perform step (2f).
 - If you are grounding through the 724 ground wire perform step (2g).
- f) Attach the tinned ground wire of the AC adapter to the ground terminal of the two-wire connector by inserting it into opening and securing with screwdriver (Fig. 5B). Continue with step (2h).

- g) Attach the tinned Model 724 ground wire to the ground terminal of the two-wire connector by inserting the tinned end into opening and securing with screwdriver (Fig. 5A). Attach the ring terminal end with a screw (not supplied) to an electrical ground (Fig. 7B). Continue with step (2h).
- h) Plug the two wire connector into the jack at the rear of the 724 monitor (Fig. 8).
- i) Insert the plug connector of the 3M 732 Dual Conductor Remote Input Jack cable into the 732 jack at the rear of the Model 724 monitor (Fig. 9).
- j) Insert the round connector from the AC adapter into the jack at the rear of the 724 monitor

Note:

Disconnect the 3M™ 2380 cord to check for visual and audible high work surface alarm condition and reconnect. If the high work surface lamp (M) is on before removing the 2380 cord, check for loose connections or high resistance to ground (>3.7 Megohms). Disconnect the 3M 2380 cord from the work surface and check the resistance to ground by attaching one lead of an ohmmeter to the connector on the work surface and the other lead to ground.

Section 3.

Installation of Model 724 Monitor without Work Surface Ground Monitoring

Wire Attachments and Grounding - See Fig. 12 for complete drawing of 724 monitor wire connections.

Tools required - Small blade, screwdriver, and wire cutter.

- a) Using a screwdriver move DIP switch #2 on the Model 724 monitor to the OFF position to deactivate the work surface audible alarm (Fig. 4).
- b) Locate the accessory package that contains a 3M™ 2380 Monitor/Table Mat Cord, Model 724 ground wire (with ring terminal), and the two-wire connector plug.
- c) Attach the 3M™ 2380 (tinned wire end) to the work surface terminal of the two-wire connector plug by inserting into opening and securing with screwdriver (Fig. 5A or 5B).
- d) Cut off the plastic cap on the end of the 3M™ 2380 cord and strip off approximately 1/2 inch of insulation and twist the stranded wire together (Fig. 6). Attach this end to an electrical ground using a ring terminal (not supplied) or by wrapping the wire around the head of a screw (Fig. 7A).

- e) Determine how you want to ground the Model 724 monitor:
- If you are grounding through the AC adapter, perform Step (3f.)
 - If you are grounding through the Model 724 ground wire, perform Step (3g.)
- f) Attach the tinned ground wire of the AC adapter to the ground terminal of the two-wire connector by inserting into opening and securing with screwdriver (Fig. 5B). Continue with Step (3h.)
- g) Attach the tinned Model 724 ground wire to the ground terminal of the two-wire connector by inserting the tinned end into opening and securing with screwdriver (Fig. 5A). Attach the ring terminal end with a screw (not supplied) to an electrical ground (Fig. 7B). Continue with Step (3h.)
- h) Plug the two wire connector into the

jack at the rear of the Model 724 monitor (Fig. 8).

⚠ Caution

Do not physically connect the 3M 2380 Monitor/Table Mat Cord and the Model 724 ground wire together. The ground wire for the work surface and the ground wire from the 724 monitor must be attached to separate electrical grounds. However, by attaching the wires to the same ground but at a different physical location, the Model 724 monitor can check for loose or lost connections to ground. This would be indicated by the high red work surface lamp (M) illuminating.

- i) Insert the plug connector of the Model 732 remote cable into the 732 jack at the rear of the Model 724 monitor (Fig. 9).
- j) Insert the round connector from the AC adapter into the jack at the rear of the Model 724 monitor.

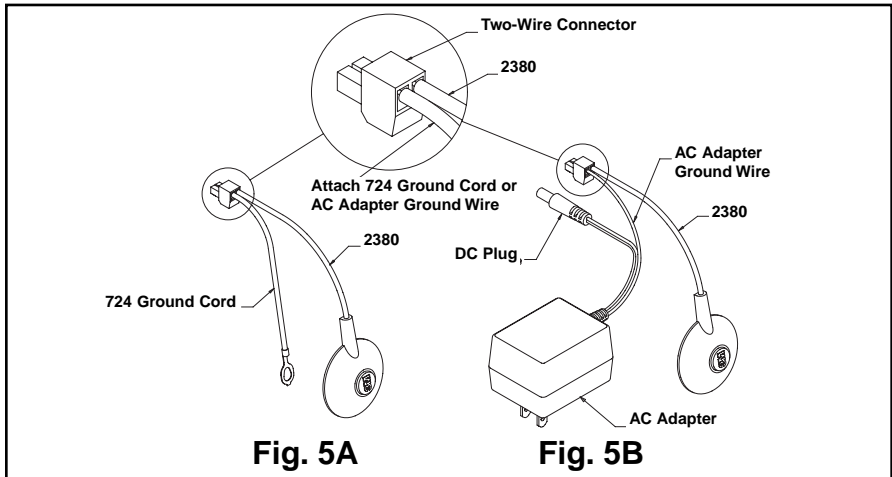

Fig. 5A & 5B - Attaching ground wire/cord and work surface cord to two-wire connector.



Fig. 6 - Cutting off table mat ground snap.



Fig. 8 - Inserting two-wire connector into rear of Model 724.



Fig. 7A - Attaching system grounds. Note work surface and unit are grounded at different locations.



Fig. 9 - Inserting 732 plug into rear of Model 724.



Fig. 7B - Grounding Model 724.

Section 4.

Selection of Test Voltage and Resistance Limit

Tools required - Small blade, screwdriver.

The Model 724 monitor allows for the selection of test voltages (9v or 16v) and resistance limits (10 Megohms or 35 Megohms). The additional ranges have been added to accommodate global ESD requirements. Selection of the operating parameters are left up to the user's discretion.

- a) Select the desired resistance and voltage limit by moving the appropriate slide switch (with screwdriver) on the side of the Model 724 monitor to the desired position (Fig. 2).

Section 5.

Mounting the 3M™ Model 724 Monitor and 3M™ Model 732 Remote

- a) Mount or position the Model 724 monitor so that the lamps are easily viewed by the operator (Figs. 10 and 11). Mount the Model 724 monitor to the underside of a work bench top or shelf through the two holes located at the top rear of the case using the two screws supplied. If using the screws is not possible, apply an appropriate amount of durable, double-sided adhesive foam tape to the case.
- b) Locate the Model 732 Dual Conductor Remote Input Jack so

that it is convenient for the operators to attach their wrist strap ground cord. Mount the remote with the screws provided.



Fig. 10 - Model 724 mounted on bench top.



Fig. 11 - Model 724 mounted under shelf or bench.

- c) Plug the AC adapter into a 3-prong grounded outlet (North American System). Outside North America use appropriate AC adapter (see specifications Section 11). The 724 monitor is ready for use.

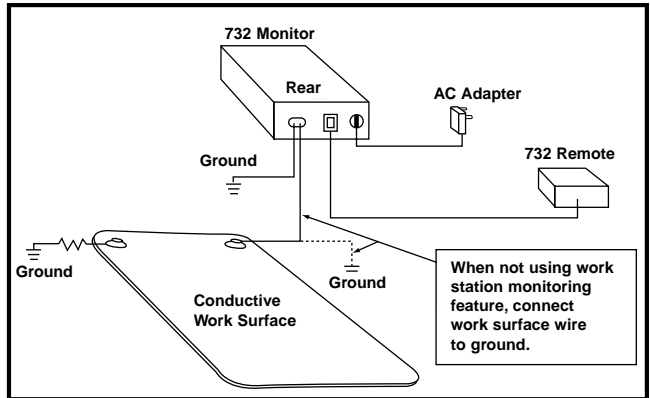

Fig. 12 - Model 724 wire connection diagram for single work station.

Section 6. Wrist Strap Connection

- a) Attach a 3M Dual Conductor Ground Cord to a 3M Dual Conductor Wrist Band (Fig.13). Plug the cord into either of the two jacks on the Model 732 Dual Conductor Remote Input Jack (Fig.14). Plugging into a jack activates the monitor for that input.
- b.) The high wrist strap red lamp (H) should illuminate and the corresponding audible alarm for the input (1 or 2) should sound indicating proper functioning of the monitor.
- c.) Slip the wrist band on your wrist. The alarm should quiet and the wrist strap high red lamp (H) should slowly extinguish. The corresponding OK wrist strap green lamp (1 or 2) should illuminate.



Fig. 13 - Connecting ground cord to wrist band.



Fig. 14 - Connecting wrist snap ground cord to Model 732.

Section 7. Fault Conditions

(Refer to Fig. 3)

Red Wrist Strap Lamp (H) Accompanied by an Audible Alarm

This indicates that a high resistance condition (greater than 10 Megohms or 35 Megohms) exists for an operator or wrist strap assembly. If two operators are connected to the monitor the high condition is with the operator whose green lamp has extinguished. Check the operator for good contact between the wrist and band. Check the ground cord and connections for continuity. Some operators have difficulty in providing sufficient continuity to the wrist band due to dry skin or arm hair. They may need to use an approved skin moisturizer or reposition the wrist band on the arm.

Note:

The operators may complain that the alarm is sounding too often until they learn to adjust the wrist band to fit securely or apply an approved skin moisturizer on a frequent basis. Please remember that the monitor is informing you that the operator is exceeding the established static

control requirement for resistance to ground when wearing a static protective wrist strap assembly. These alarms alert the operator when sensitive electronics are possibly being exposed to static electricity. Prior to incorporating the work station monitor into your static control process, the operator was unaware of these events.

Yellow Wrist Strap Lamp (L) with no Audible Alarm

▲ Caution

This indicates that a low resistance condition (less than 1.5 Megohms) exists between the operator and ground. One or both of the one megohm current-limiting resistors are being bypassed. A low resistance condition can be caused by touching a grounded object or by standing on a conductive surface.

Red Work Surface Lamp (M)

This indicates that a high resistance condition (greater than 3.7 Megohms) exists across the conductive layer of the work surface and/or the ground connections. Check the work surface, ground cords, and the connections for continuity. Note the audible alarm may also sound if selected.

Section 8.

3M™ Model 3057 Standby Jack

Since the activating switches are located in the Models 732/733 Dual Conductor Remote Input Jack, the normal operating procedure is for the operators to disconnect their cords from the remotes when leaving the work station. However, an optional standby jack (3M™ Model 3057) that allows the wrist strap ground cord to remain plugged into the remotes is available. Simply attach it to any convenient location then disconnect the cord from the wrist band and attach it to the standby jack (Fig. 15). The OK green lamp (1 or 2) on the Model 724 monitor will illuminate upon connection. The low yellow lamp (L) will slowly flash if the standby jack is grounded. It can be grounded by attaching a ground wire to the screws or back plate. It can also be grounded if the plate is attached to a grounded metal surface. The operator should reconnect the wrist strap ground cord to their wrist band upon returning to the work station.



Fig. 15 - Attach cord to Model 3057 standby jack.

Section 9.

3M™ Model 733 Dual Conductor Remote Input Jack

The Model 733 Dual Conductor Remote Input Jack is used to separate the two wrist strap jacks on the Model 732 that connect to a Model 724 Monitor. This provides a separation up to approximately 10 feet apart. This is done using a second remote input module (Model 733) in conjunction with the Model 732 remote input module originally supplied with the Model 724 monitor. Two separate work stations can also be created using the Model 733 and the 3M™ Model 2389 (10 ft.) Monitor/Table Mat Interconnect Cord. Instructions for creating two separate work stations are included with the purchase of the 3M™ 2389 cord (Fig. 17).

Section 10.

Installation of 733 Remote

- a) Insert the plug connector of the Model 733 Dual Conductor Remote Input Jack cable into the Model 733 jack at the rear of the Model 724 monitor (Fig. 16).
- b) Fully insert the small plastic plug that comes with the kit into the #2 wrist strap input on the Model 732 Dual Conductor Remote Input Jack. This disables the #2 input and prevents a situation where two users would simultaneously attempt to use the input lines to the Model 724.

c) Position and mount both remote input jacks in convenient locations.



Fig. 16 - Inserting Model 733 plug into rear of Model 724

Section 11. Verification Procedure for the Model 724 Monitor

The Model 724 Monitor cannot be recalibrated after the initial factory calibration. However, the following steps can be used to determine if the Model 724 is operating within its specifications.

Equipment Needed:

- Small blade screwdriver.
- Resistance Substitution Box (RSB), 1 Ohm to 45 Megohms $\pm 1\%$.

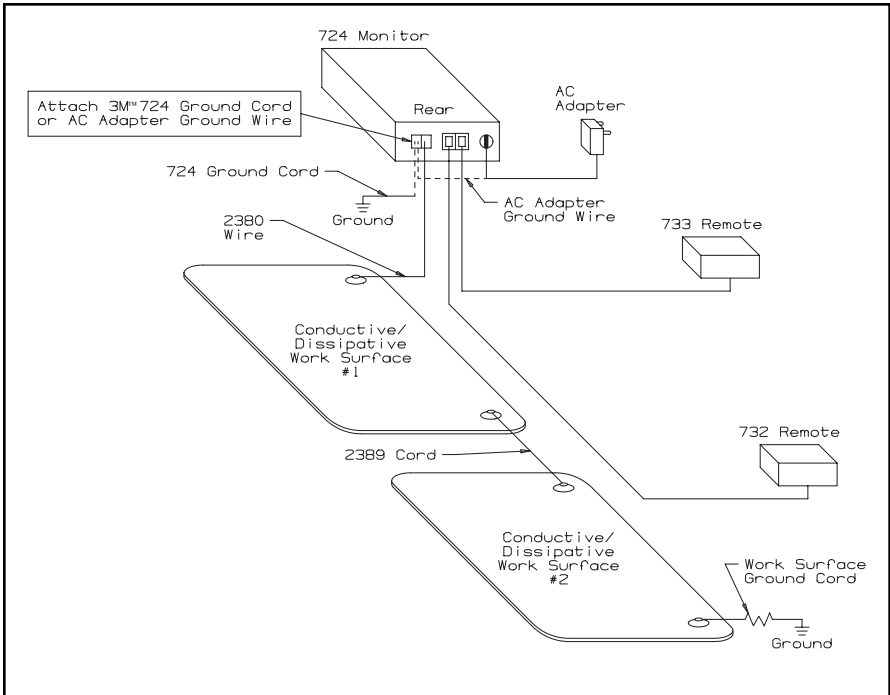

Fig. 17 - Model 724 wire connection diagram for two work stations.

- One two-conductor cable with standard 3.5 mm (miniature) phone plug attached on one end and appropriate connectors on the other end to connect to RSB.

Note:

Two-conductor cable must have an isolation resistance of >1 Gigohm between conductors. Two separated wires may also be used to obtain higher isolation resistance.

- Two wires with alligator clips.
- Ohmmeter capable of measuring to 45 Megohms $\pm 0.5\%$, to verify the RSB.

Procedure:

Work Surface

- Access the DIP switches SW1 and SW2 through a slot located at the bottom of the chassis. Adjust SW1 to the LOUD position and SW2 to the ON position with a small screwdriver (Fig 4).
- Plug in the AC adapter. Note that the red high work surface lamp (M) is illuminated with an audible alarm (slow chirping beep).
- Adjust DIP switch SW1 to the SOFT position. Note that the loudness of the alarm decreases.
- Adjust DIP switch SW2 to the OFF position. Note that the audible alarm is silenced.

- Attach the 3M™ 2380 Monitor/Table Mat Cord and the 724 ground wire to the RSB using the two wires with alligator clips. Set the resistance as follows and observe Model 724 monitor output:
 - 3.1 Megohms – Red work surface lamp (M) OFF.
 - 4.3 Megohms – Red work surface lamp (M) ON.

- Disconnect the cords from the RSB.
- Connect the ring terminal end of the Model 724 ground wire to the metal snap of the 3M™ 2380 Monitor/Table Mat Cord. The red work surface lamp (M) should now be OFF.

Wrist Strap

Set Resistance Limit 10 Megohms and Test Voltage 9v (Fig. 2).

- Connect the two-wire cable with 3.5 mm phone plug into the #1 input of the Model 732 Dual Conductor Remote Input Jack and attach the other end to the RSB. Set the resistance as follows and observe the Model 724 monitor output:
 - 1.3 Megohms – Yellow low lamp (L) flashing, green (OK) lamp (1) ON, and audible alarm OFF.
 - 1.7 Megohms - Yellow low lamp (L) OFF, green (OK) lamp (1) ON, and audible alarm OFF.

8.5 Megohms – High red wrist strap lamp (H) OFF, green (OK) lamp (1) ON, and audible alarm OFF.

11.5 Megohms – High red wrist strap lamp (H) ON, audible alarm ON (continuous tone), and green (OK) lamp (1) OFF.

- i) Repeat step (6h) for input #2 of the 732 Dual Conductor Remote Input Jack. Audible alarm will be a fast chirping beep.

Set Resistance Limit 35 Megohms and Test Voltage 9v (Fig. 2).

- j) Test as in step (6h) above. However, set the resistance as follows and observe the 724 monitor output:

1.3 Megohms – Yellow low lamp (L) flashing, green (OK) lamp (1) ON, and audible alarm OFF.

1.7 Megohms – Yellow low lamp (L) OFF, green (OK) lamp (1) ON, and audible alarm OFF.

29.8 Megohms – High red wrist strap lamp (H) OFF, green (OK) lamp (1) ON, and audible alarm OFF.

40.2 Megohms – High red wrist strap lamp (H) ON, audible alarm ON (continuous tone), and green (OK) lamp (1) OFF.

- k) Repeat step (6j) for input #2 of the 732 Dual Conductor Remote Input Jack. Audible alarm will be fast chirping beep.

Set Resistance Limit 10 Megohms and Test Voltage 16v (Fig. 2).

- l) Connect the two-wire cable with 3.5 mm phone plug into the #1 input of the Model 732 Dual Conductor Remote Input Jack and attach the other end to the RSB. Set the resistance as follows and observe the 724 monitor output:

1.3 Megohms – Yellow low lamp (L) flashing, green (OK) lamp (1) ON, and audible alarm OFF.

1.7 Megohms – Yellow low lamp (L) OFF, green (OK) lamp (1) ON, and audible alarm OFF.

8.5 Megohms – High red wrist strap lamp (H) OFF, green (OK) lamp (1) ON, and audible alarm OFF.

11.5 Megohms – High red wrist strap lamp (H) ON, audible alarm ON (continuous tone), and green (OK) lamp (1) OFF.

- m) Repeat step (6l) for input #2 of the Model 732 Dual Conductor Remote Input Jack. Audible alarm will be fast chirping beep.

Set Resistance Limit 35 Megohms and Test Voltage 16v (Fig. 2).

n) Test as in step (6l) above. However, set the resistance as follows and observe the 724 Monitor output:

1.3 Megohms - Yellow low lamp (L) flashing, green (OK) lamp (1) ON, and audible alarm OFF.

1.7 Megohms - Yellow low lamp (L) OFF, green (OK) lamp (1) ON, and audible alarm OFF.

29.8 Megohms - High red wrist strap lamp (H) OFF, green (OK) lamp (1) ON, and audible alarm OFF.

40.2 Megohms - High red wrist strap lamp (H) ON, audible alarm ON (continuous tone), and green (OK) lamp (1) OFF.

o) Repeat step (6n) for input #2 of the Model 732 Dual Conductor Remote Input Jack. Audible alarm will be fast chirping beep.

Section 12. Specifications

724 Monitor Size:
6.5 x 3.125 x 1.375 in.
(16,5 x 7,9 x 3,5 cm)

732/733 Remote Input Jack Size:
2.75 x 1.0 x 1.0 in.
(7,0 x 2,5 x 2,5 cm)

Power Supply Requirements:
Input: 120 Vac +/-10%
(North America)
Output: 25 Vdc @ 50 mA
rated load

Output Plug Polarization:
Center Negative

Output Plug Dimensions: 5,5mm O.D.
x 2,1mm I.D. x 9,5mm Length

Accuracy: +/-15%

Test Voltage: 9 VDC / 16 VDC
Open circuit

Test Current: Less than 3 microamps

Environmental Operating Conditions:

Temperature:
Maximum 110°F / 43°C
Minimum 50°F / 10°C

Humidity:
Maximum 75% R.H.

Section 13. Parts Included

- 1 ea. Model 724 Work Station Monitor
- 1 ea. Model 732 Dual Conductor Remote Input Jack
- 1 ea. AC Adapter (North America Only for outside North America see Power Supply Requirements (Section 12))
- 1 ea. 724 Ground Cord
- 1 ea. 2380 Monitor/Table Mat Cord
- 1 ea. Two-Wire Connector
- 4 ea. Mounting Screws
- 2 ea. Wire Management Clips
- 1 ea. User Instruction Manual

Section 14.

Required Accessories and Optional Available Parts

Model No.	Description	Size
2361	Dual Conductor Fabric Wrist Strap*	small
2362	Dual Conductor Fabric Wrist Strap*	medium
2363	Dual Conductor Fabric Wrist Strap*	large
2364	Dual Conductor Fabric Wrist Band	small
2365	Dual Conductor Fabric Wrist Band	medium
2366	Dual Conductor Fabric Wrist Band	large
2368	Dual Conductor Fabric Wrist Band	adjustable
2381	Dual Conductor Metal Wrist Strap*	small
2382	Dual Conductor Metal Wrist Strap*	medium
2383	Dual Conductor Metal Wrist Strap*	large
2384	Dual Conductor Metal Wrist Band	small
2385	Dual Conductor Metal Wrist Band	medium
2386	Dual Conductor Metal Wrist Band	large
2360	Dual Conductor Coil Cord	5 ft. (1,5 m.)
2370	Dual Conductor Coil Cord	10 ft. (3,0 m.)
2371	Dual Conductor Coil Cord	20 ft. (6,0 m.)
2380	Monitor-Table Mat Replacement Cord (No resistor)	6 ft. (1,8 m.)
2389	Monitor-Table Mat Replacement Cord (No resistor)	10 ft. (3,0 m.)
3057	Stand-By Jack	1.9 x 1.3 x 1.1 in. (4,8 x 3,3 x 2,8 cm)
732	Replacement Remote Input Jack	6.5 x 3.1 x 1.4 in. (16,5 x 7,9 x 3,5 cm)
733	Dual Remote Splitter Kit	6.5 x 3.1 x 1.4 in. (16,5 x 7,9 x 3,5 cm)

* Includes band & cord

Section 15.

Additional Wrist Strap Monitoring Information

Suggested reading on wrist strap requirements and wrist strap monitoring:

- EIA 625 - Requirements for Handling Electrostatic-Discharge-Sensitive (ESDS) Devices.
- EN100015/1 - Protection of Electrostatic Sensitive Devices.
- 3M Tech. Response #123 - Pulsed

Current vs. Constant Current in Work Station Monitors.

- 3M Static Digest Issue No.1, 1998 - Disc Drive Industry - Static Control Considerations.

Note:

The 3M references are available by calling 3M Electronic Handling & Protection Division Customer Service Department at 1-800-328-1368. Industry standards (EIA & EN) are available through Global Engineering Documents at 1-800-854-7179.

Section 16.

Warranty

Limited Warranty - 3M expressly warrants that for a period of one year from the date of purchase, 3M static control products will be free of defects in materials (parts) and workmanship (labor).

Defects occurring during the warranty period will be repaired or products will be replaced at 3M's option and expense if 3M receives notice during the warranty period. Defective products must be returned to 3M with proof of purchase date.

Warranty Exclusions - THE FOREGOING EXPRESS WARRANTY IS MADE IN LIEU OF ALL OTHER PRODUCT WARRANTIES, EXPRESS AND IMPLIED.

INCLUDING FITNESS AND MERCHANT ABILITY. The express warranty will not apply to defects of damage due to accidents, neglect, misuse, alterations, operator error, or failure to properly maintain, clean, or repair products.

Limit of Liability - In no event will 3M or Seller be responsible or liable for special, incidental, or consequential losses or damages, whether based in tort or contract. Fulfillment of 3M's warranty obligations will be Customer's exclusive remedy and 3M's and Seller's limit of liability for any breach of warranty or otherwise.