

**TRESTON®**

# ESD protective products for the electronics industry

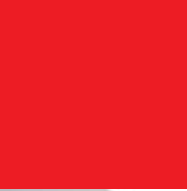



## ESD PROTECTED FURNITURE FOR PROFESSIONALS

Treston specialises in industrial furniture and storage systems for the electronics industry. We manufacture ESD safe workbenches, drawer cabinets, trolleys, chairs and bins to give just a few examples. By using high quality Treston ESD products you will help safeguard your components and end products from harmful ESD related problems. Creating an EPA requires that every step along the way from component receipt to finished product is considered, and that certified clothing, floors, shoes, storage and furniture are used to maintain protection throughout. By combining the use of high quality products and staff training ESD protection can be effectively maintained.

In this catalogue Treston introduces a new full range of chairs, tilt workbenches etc.

## QUALITY

Treston is an ISO 9001 registered company. Certification includes the design, development, manufacture and marketing of the company's range of storage equipment and industrial furniture. Most of our industrial furniture also has the GS-quality approval (TÜV). TRESTON ESD products and their materials are to IEC 61340-5-1 international standards. The ESD products meet with cleanroom requirements and are to the international standard EN ISO 14644-1, class 7. Equivalent Finnish standard is FS 209 E, where the number of particles is under 10 000 per cubic metre of air.

## ESD MATERIAL

### Static dissipative high pressure laminate

- resistance surface to ground  $10^6 - 10^8$  ohm
- surface to surface  $10^6 - 10^9$  ohm
- resistant to heat, solder flux, most chemicals and solvents

### Semiconductive epoxy powder coated steel

- surface resistivity  $10^5 - 10^9$  ohm

### Semiconductive polypropylene = PP

- surface resistivity  $10^3...10^6$  ohm
- volume resistivity  $10^3...10^6$  ohm
- temperature tolerance  $-20...+70^\circ\text{C}$

### Semiconductive polystyrene = PS

- surface resistivity  $10^3...10^6$  ohm
- volume resistivity  $10^3...10^6$  ohm
- temperature tolerance  $-40...+65^\circ\text{C}$

## COLOURS

Colours reproduced here are as accurate as print techniques allow.

light grey  
RAL 7035



grey  
RAL 7045

# contents

Adjustable workbenches WB • height adjustment by allen key, retractable handle, by electric motor, tilt adjustment	4-7
Workstation WS • height adjustment by allen key, retractable handle, by electric motor	8
Workbenches TP/TPH • height adjustment by allen key	9--11
Moveable benches CTR/SAP	5, 10
Steel cabinets ML	12
Light steel cabinets LMC	13
Lighting units OL/SL	14
Computer accessories, bottle holder	15
Universal trolley WTR	16
Industrial trolley IT	17
Adjustable trolleys TRTA	18
Reel holder trolley RRT ESD	19
Chairs X/KJ	20-21
Footrest JT	21
Screen system	22-23
Shelf cabinets HK	24
Small parts shelving PH, wrist straps, ESD earthing boxes, bench top ESD mats, ESD flooring, earthing cable	25
Small part storage cabinets 291/294/551/554 ESD	26
Turntable assemblies 12-550 ESD, cabinet stands and trolley BS/BT ESD	27
Storage cabinets, turntable assemblies	28-29
ESD bins	30-31
Bin stands and trolley BS/BT ESD	32

# adjustable workbenches WB



The new generation WB workbench has been designed for use in demanding assembly environments. The concept is one of simplicity and good ergonomics, allowing each bench to be adapted to a variety of tasks. Electric motor, manual hand crank or allen key height adjustment cater for standing or seated users, while the generous worktop depth and broad accessory range ensure that everything is within easy reach. Another feature of this new design is the flush bench footprint; benches can be placed side-by-side, back-to-back, or right up against walls with no unnecessary gaps. You can design your workstation to fit your needs perfectly.

## Workbench WB

Worktop height is adjusted by manual allen key, retractable handle or electric motor between 700...1100 mm. The adjustment system in both cases utilises interlocking aluminium profiles, providing a strong, rigid frame. Steel frame parts are epoxy powder coated light grey paint, RAL 7035. Worktops are 26 mm ESD-laminate, adjustable feet are provided for fine levelling.

Allen-key adjustable bench. Load capacity 250 kg equipment static u.d.l.

Code	Worktop mm
WB 811 ESD	800 x 1073
WB 815 ESD	800 x 1500
WB 818 ESD	800 x 1800

Handle adjustable bench. Load capacity 200 kg equipment static u.d.l. A cable tidy is included.

Code	Worktop mm
WB 811 C ESD*	800 x 1073
WB 815 C ESD	800 x 1500
WB 818 C ESD	800 x 1800

Electric adjustable bench. Adjustment speed using the motor is 19 seconds min. to max. Load capacity 200 kg equipment static u.d.l. A cable tidy is included.

Code	Worktop mm
WB 811 EL ESD*	800 x 1073
WB 815 EL ESD	800 x 1500
WB 818 EL ESD	800 x 1800



\*) To order



### 1. Corner worktop WB 1212 CT ESD

A corner worktop can be used with two WB benches to create a 90 deg. angle setup. This unit consists of a worktop and all necessary components. It requires no additional leg frames, simply mounting to the standard benches with the brackets provided. Load capacity for this worktop is 50 kg. Dimensions 1153 x 1153 mm. Not suitable for WB EL or WB C versions.

### 2. Side worktop WB 804 ST ESD

This new side worktop can be installed on either the right or left hand side of a WB bench to increase the surface area. Installation can be either at the same height, or lower than the main worktop with the brackets provided. Load capacity for this side worktop is 50 kg, and it is suitable for all WB models in the range. Dimensions 800 x 400 mm.

### 3. Moveable bench CTR 705 ESD

Height adjustment with allen key between 690..990 mm. A lower shelf is integrated. Steel frame parts are epoxy powder coated light grey paint, RAL 7035. Semiconductive swivel castors Ø 100 mm of which two are braked. Load capacity 75 kg/shelf static u.d.l.

### 4. Tilt workbench WB-TILT

Worktop tilt is adjusted by manual allen key, retractable handle or electric motor between 0..60°. Load capacity for this worktop is 100 kg static u.d.l. Construction as WB. Made to order.



NEW!



#### Tilt adjustment by allen key

Height adjustment by allen key	Height adjustment by handle	Height adjustment by electric motor	Worktop mm
WB 811 TILT ESD*	WB 811 C TILT ESD*	WB 811 EL TILT ESD*	700 x 1073
WB 815 TILT ESD*	WB 815 C TILT ESD*	WB 815 EL TILT ESD*	700 x 1500
WB 818 TILT ESD*	WB 818 C TILT ESD*	WB 818 EL TILT ESD*	700 x 1800

#### Tilt adjustment by handle

Height adjustment by allen key	Height adjustment by handle	Height adjustment by electric motor	Worktop mm
WB 811 TILT C ESD*	WB 811 C TILT C ESD*	WB 811 EL TILT C ESD*	700 x 1073
WB 815 TILT C ESD*	WB 815 C TILT C ESD*	WB 815 EL TILT C ESD*	700 x 1500
WB 818 TILT C ESD*	WB 818 C TILT C ESD*	WB 818 EL TILT C ESD*	700 x 1800

#### Tilt adjustment by electric motor

Height adjustment by allen key	Height adjustment by handle	Height adjustment by electric motor	Worktop mm
WB 811 TILT EL ESD*	WB 811 C TILT EL ESD*	WB 811 EL TILT EL ESD*	700 x 1073
WB 815 TILT EL ESD*	WB 815 C TILT EL ESD*	WB 815 EL TILT EL ESD*	700 x 1500
WB 818 TILT EL ESD*	WB 818 C TILT EL ESD*	WB 818 EL TILT EL ESD*	700 x 1800



\*) To order

# adjustable workbenches WB



Modular accessories are available to provide ergonomic storage and presentation of parts and equipment. The upper section can be used as one module, or divided into two modules horizontally using the AKK accessory frame.

## Accessories

- steel parts are epoxy powder coated light grey paint, RAL 7035.
- shelves are of 26 mm ESD-laminate
- WB 811 benches can be fitted with size 100 accessories in one module
- WB 815 benches can be fitted with size 70 accessories in two modules
- WB 818 benches with one size 70 and one size 100 module.

## 1. Upright profiles AL2X-W

Needed for mounting accessories to benches. Includes 2 vertical and 1 horizontal profile. With 3 cable clips (CC8).

Code	Dims mm	Suitable for
AL2X 110 W	1063 x 900	WB 811 ESD
AL2X 150 W	1489 x 900	WB 815 ESD
AL2X 180 W	1789 x 900	WB 818 ESD

## 2. Accessory frame AKK

The accessory frame divides the space between the upright profiles into 2 modules. AKK frame includes 1 vertical and 1 horizontal profile. Useable height 500 mm.

Code	Dims mm	Suitable for
AKK 150	690 + 690	WB 815 ESD
AKK 180	690 + 990	WB 818 ESD

## 3. Shelf ALH

Height adjustable shelf, 26 mm ESD-laminate. Load capacity 50 kg.

Code	Dims mm	Suitable for
ALH 110 ESD	310 x 1073	WB 811 ESD
ALH 150 ESD	310 x 1500	WB 815 ESD
ALH 180 ESD	310 x 1800	WB 818 ESD

## 4. Adjustable shelf ASH

Continuous adjustment for depth, height and angle. Shelf of 26 mm ESD-laminate. Lipped front edge. Load capacity 35 kg static load. Mount on accessory frame.

Code	Dims mm	Suitable for
ASH 70 ESD	400 x 660	WB 815/818 ESD
ASH 100 ESD	400 x 960	WB 811/818 ESD

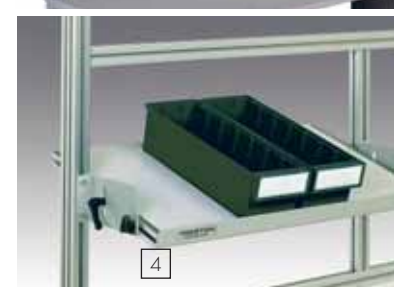
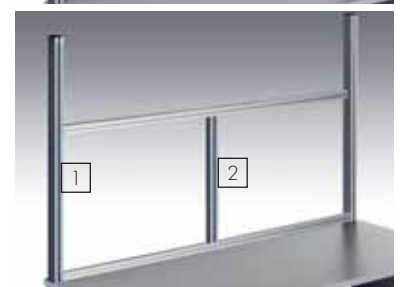
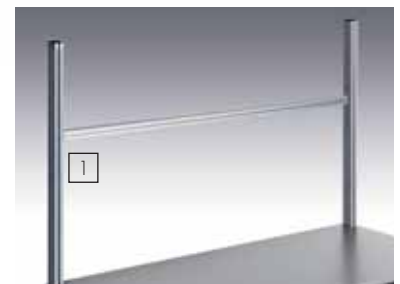

## 5. Bin profile BP

Aluminium profile for TRESTON stacking and picking bins. Mount on accessory frame.

Code	Dims mm	Suitable for
BP 70 ESD	length 685	WB 815/818 ESD
BP 100 ESD	length 985	WB 811/818 ESD

## 6. Perforated panel ARL

Perforated steel panel with 9 mm perforations at 38 mm centres. Mount on accessory frame with screws.

Code	Dims mm	Suitable for
ARL 70	500 x 685	WB 815/818 ESD
ARL 100	500 x 985	WB 811/818 ESD

## 7. Support bracket HSB

Support bracket of steel for suspending power tools and lighting units. Mount on upright profiles.

Code	Length mm	Suitable for
HSB 110	1073	WB 811 ESD
HSB 150	1500	WB 815 ESD
HSB 180	1800	WB 818 ESD

## 8. Swivel arm with tray AKV

Lockable, angle adjustable steel tray with swivel radius of 360°. Length of swivel arm 590 mm. Max. load 15 kg. Semiconductive epoxy powder coated steel. Mount on upright profile.

Code	Tray mm	Suitable for
AKV 400 ESD	210 x 460	WB ESD

## 9. Keyboard shelf WKA

Keyboard shelf with swivel arm. Semiconductive epoxy powder coated steel. Load capacity 15 kg. Arm length 220 mm.

Code	Shelf mm	Suitable for
WKA ESD	220 x 500	WB ESD

## 10. Document stand WDA

Document stand A3 with swivel arm. Semiconductive epoxy powder coated steel. Arm length 220 mm. Tilt 75°.

Code	Stand mm	Suitable for
WDA ESD	440 x 300	WB ESD

## 11. Cable tidy WBCT

Mount on frame. A cable tidy is standard equipment on motor and retractable handle bench

Code	Dims mm	Suitable for
WBCT 110*	64 x 204 x 948	WB 811 ESD
WBCT 150	64 x 204 x 1375	WB 815 ESD
WBCT 180	64 x 204 x 1675	WB 818 ESD

## 12. Lower shelf AT-WB

Height adjustable lower shelf, 26 mm ESD-laminate. Load capacity 50 kg. Mount between aluminium profiles.

Code	Dims mm	Suitable for
AT 110 WB ESD*	400 x 828	WB 811 ESD
AT 150 WB ESD*	400 x 1255	WB 815 ESD
AT 180 WB ESD*	400 x 1555	WB 818 ESD

## 13. Cable clip set CC

The cable clip set will hold cables etc. securely and neatly in place along the bench frame. The clips locate in the 8 mm profile slot.

Code	Set	Suitable for
CC8	5 pieces	AL2X

\*) To order

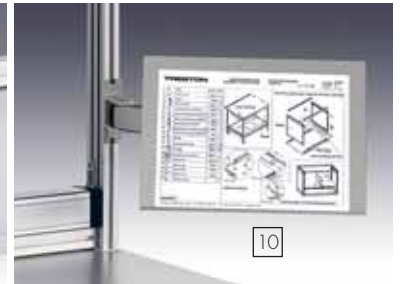

## 14. Cable channels

May be fitted with a choice of components, ordered separately. All meet with CE requirements. 3 m cable is included. Supplied wired and ready for use.

A finished CJK 70 SET includes 3 double sockets (E1) and a switch (E2). (Other SETs are also available.)

Code	Dims mm	Suitable for
CJK 70	profile 631	WB 815/818 ESD
CJK 100	profile 931	WB 811/818 ESD
CJK 70 SET	3 double sockets (E1) and a switch (E2)	WB 815/818 ESD
COMPONENTS		
E1	Double socket	
E2	Switch	
E3	Automatic fuse 10 A	
E4	Automatic fuse/earth leakage switch 10 A/30 mA	
E5	Emergency-stop-switch	
E6	Data connector/shielded for Cat.6 cable	
E7	Data connector/without screen for Cat.5 cable	
E8	Pneumatic, quick coupling 3/8"	

# workstation WS



This flexible and versatile workstation can be adjusted for seated or standing operation. L-shaped frame for good leg room. Height adjustment of worktops by hydraulic electric motor, hydraulic retractable handle or allen-key between 700...1200 mm. The adjustment system is based on a rigid, sliding aluminium frame. Steel frame parts are semiconductive epoxy powder coated steel, RAL 7035. Worktops are of 26 mm ESD-laminate, adjustable feet are provided for fine levelling. Load capacity 150 kg u.d.l. per workstation. This unit consists of frame, worktop, shelf 310 x 900 mm, rear worktop 310 x 1060 mm with a rear lip, tool support and cable tidy. The rear worktop can be tilted.

Code	Worktop mm	Model
WS 511 ESD	550 x 1060	Allen key
WS 515 ESD	550 x 1500	Allen key
WS 511 C ESD	550 x 1060	Retractable handle
WS 515 C ESD	550 x 1500	Retractable handle
WS 511 EL ESD	550 x 1060	Electric motor
WS 515 EL ESD	550 x 1500	Electric motor

## accessories

### 1. Adjustable shelf WAS 90 ESD

Continuous adjustment for depth, height and angle. Shelf of 26 mm ESD-laminate, size 400 x 870 mm. Lipped front edge. Static load capacity 35 kg.

### 2. Bin profile BP 90 ESD

Aluminium profile for stacking and picking bins. Length 895 mm. Static load capacity 15 kg.

### 3. Extra shelf WFS 90 ESD

26 mm ESD-laminate, size 310 x 900 mm. Static load capacity 50 kg.

### 4. Rear worktop WBS 311 ESD

Tilted between 0...20°, size 310 x 1060 mm. Rear lip. 26 mm ESD-laminate. Load capacity 80 kg.

### 5. Keyboard shelf WKA ESD

Keyboard shelf with swivel arm. Epoxy powder coated steel. Arm length 220 mm, shelf 220 x 550 mm. Load capacity 15 kg.

### 6. Document stand WDA ESD

Document stand A3 with swivel arm. Semiconductive epoxy powder coated steel: light grey. Arm length 220 mm, stand 440 x 300 mm. Tilt 75°.

### 7. Footrest WJT ESD

Footrest is adjustable for height and tilt. Mounted on WS frame. Footrest of polystyrene, connectors of steel. Size 500 x 370 mm.

### 8. Cable clip set CC

The cable clip set will hold cables etc. securely and neatly in place along the bench frame. The clips locate in the 10 mm profile slot. 5 pcs/set.

### 9. Cable channels WJK 90

May be fitted with a choice of components, ordered separately. All meet with CE requirements. Cable channel is isolated from the workbench. 3 m cable is included. Profile 840 mm  
Components:

- E1 Double socket
- E2 Switch
- E3 Automatic fuse 10 A
- E4 Automatic fuse/earth leakage switch 10 A/30 mA
- E5 Emergency-stop-switch
- E6 Data connector/shielded for Cat.6
- E7 Data connector/without screen for Cat.5
- E8 Pneumatic, quick coupling 3/8"



# workbenches TP



These ergonomic workbenches are suitable for light assembly. The modular construction allows many possibilities when planning a layout

## 1. Workbench TP

Height adjustment with allen-key between 650...900 mm. Frames are of epoxy powder coated steel in grey RAL 7045. The worktops are of 26 mm ESD-laminate.

## 2. Angle extension TP -K

Each standard TP-workbench may also be supplied as an angle extension. Stock sizes are shown.

## 3. Corner workbench TP KK

A corner workbench can be used with two TP-K benches to create a 90 deg. angle setup. This unit consists of a worktop, two side frames and a leg in the middle. Load capacity 150 kg u.d.l.

>>>

No.	Code	Worktop mm	Load capacity static u.d.l.
1	TP 510 ESD	500 x 1000	150 kg
	TP 710 ESD	700 x 1000	300 kg
	TP 712 ESD	700 x 1200	300 kg
	TP 715 ESD	700 x 1500	300 kg
	TP 718 ESD	700 x 1800	300 kg
	TP 915 ESD	900 x 1500	300 kg
	TP 918 ESD	900 x 1800	300 kg
	2	TP 510K ESD	500 x 1000
TP 712K ESD		700 x 1200	150 kg
3	TP 707 KK ESD	1100 x 1100	150 kg
	TP 909 KK ESD	1300 x 1300	150 kg



# workbenches TPH/SAP



## 1. Workbench TPH

Height adjustment with allen-key between 650..900 mm. Workbench with upright profiles and a laminate shelf, depth 310 mm, height adjustment between 1080..1550 mm, load capacity 50 kg. Frames are of epoxy powder coated steel in grey RAL 7045. The worktops are of 26 mm ESD-laminate. There are a large range of workbench accessories available.

## 2. Corner workbench TPH KK

A corner workbench can be used with two TPH benches to create a 90 deg. angle setup. This unit consists of a worktop and all necessary components. Load capacity 150 kg u.d.l.

## 3. Moveable bench SAP

Construction as TP. Height adjustment with allen key between 650..900 mm. Swivel castors Ø 100 mm two semiconductive and two with brakes. Load capacity 150 kg. Lower shelf available separately.

## 4. Lower shelf AT

For moveable bench.

No.	Code	Worktop mm	Load capacity static u.d.l.
1	TPH 712 ESD	700 x 1200	300 kg
	TPH 715 ESD	700 x 1500	300 kg
	TPH 718 ESD	700 x 1800	300 kg
	TPH 915 ESD	900 x 1500	300 kg
	TPH 918 ESD	900 x 1800	300 kg
2	TPH 707 KK ESD	1100 x 1100	150 kg
	TPH 909 KK ESD	1300 x 1300	150 kg
3	SAP 507 ESD	500 x 700	150 kg
	SAP 710 ESD	700 x 1000	150 kg
	SAP 715 ESD	700 x 1500	150 kg
4	AT 507 ESD	500 x 700	40 kg
	AT 710 ESD	700 x 1000	40 kg

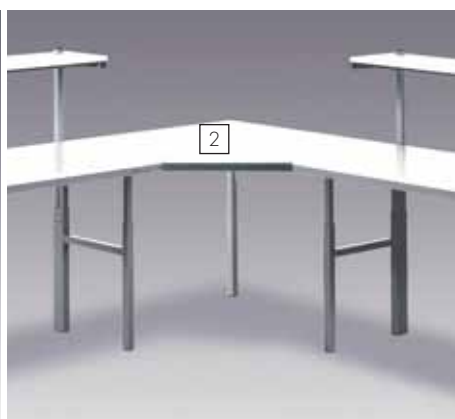

Accessories are mounted between vertical C-profiles. Steel parts are epoxy powder coated in light grey RAL 7035. The shelves are 26 mm ESD-laminate

### 1. Metal shelf TH

Adjustment for depth, height and angle. For stacking and picking bins. Load capacity 30 kg. Semiconductive epoxy powder coated steel in light grey RAL 7035.

### 2. Bin profile BP

Aluminium profile for stacking and picking bins.

### 3. Auxiliary shelf SH

Height adjustable shelf. 26 mm ESD-laminate.

### 4. Perforated panel RL

Robust, perforated steel panel. 9 mm perforations at 38 mm centres. Mount on TPH-benches with connectors RK 1. Can also be attached to a wall with screws (included).

### 5. Tool and lighting support KT

For suspending power tools and lighting units. Includes one C-profile bar with sliding hook.

### 6. Cable tidy TPHCT

Mounted between C-profiles below worktop. Perforated epoxy powder coated steel.

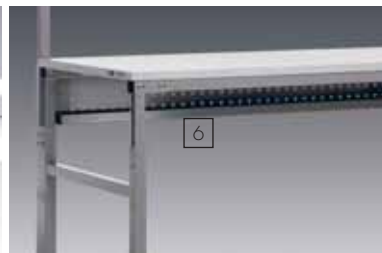
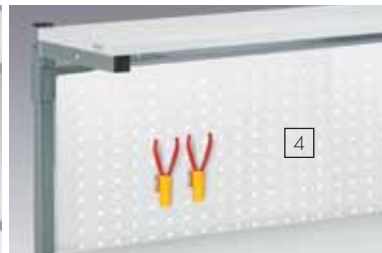

No.	Code	Dims D x W x H mm	Load	Suitable for
1	TH 120 ESD	145 x 1119	30 kg	TPH 712
	TH 150 ESD	145 x 1419	30 kg	TPH 715/915
	TH 180 ESD	145 x 1719	30 kg	TPH 718/918
2	BP 120 ESD	profile 1115	15 kg	TPH 712
	BP 150 ESD	profile 1415	15 kg	TPH 715/915
	BP 180 ESD	profile 1715	15 kg	TPH 718/918
3	SH 150 ESD	310 x 1500	50 kg	TPH 715/915
	SH 180 ESD	310 x 1800	50 kg	TPH 718/918
4	RL 120	750 x 1115		TPH 712
	RL 150	750 x 1415		TPH 715/915
	RL 180	750 x 1715		TPH 718/918
	RK 1	connectors (4 pcs)		TPH
5	KT 120	600 x 1200		TPH 712
	KT 150	600 x 1500		TPH 715/915
	KT 180	600 x 1800		TPH 718/918
	Extra C-profile			
	SPR 150	1500		KT 150
6	TPHCT 120	45 x 205 x 1115		TPH 712
	TPHCT 150	45 x 205 x 1415		TPH 715/915
	TPHCT 180	45 x 205 x 1715		TPH 718/918
7	CKV 400	tray 210 x 460	15 kg	TPH
8	CC 12	5 pcs/set		TPH
9	TJK 120	profile 1058		TPH 712
	TJK 150	profile 1358		TPH 715/915
	TJK 180	profile 1658		TPH 718/918
	TJK 150 SET	includes 3 x E1, 1 x E2		TPH 715/915
	TJK 180 SET	includes 3 x E1, 1 x E2		TPH 718/918
	COMPONENTS			
E1	Double socket			
E2	Switch			
E3	Automatic fuse 10 A			
E4	Autom./earth leakage switch 10 A/30 mA			
E5	Emergency-stop-switch			
E6	Data connector/shielded for Cat.6			
E7	Data connector/without screen for Cat.5			
E8	Pneumatic, quick coupling 3/8"			

### 7. Swivel arm with tray CKV

Swivel arm with lockable, angle adjustable steel tray. Load 15 kg. Semiconductive epoxy powder coated steel. Mount on C-profile.

### 8. Cable clip set CC

The clips locate in the 12 mm profile slot. 5 pcs/set.

### 9. Cable channel

May be fitted with a choice of components, ordered separately. 3 m cable is included. All meet with CE requirements. The finished TJK 150 SET and TJK 180 SET include 3 double sockets (E1) and a switch (E2). (Other SETs are also available.)

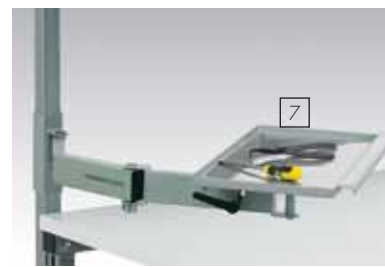

# metal cabinets ML



Steel cabinet ML 04 ESD includes ESD mat on top, handle and 4 castors Ø 100 mm, two semiconductive and two with brakes.

Outer height mm	inner height mm
60	50
120	110
140	130
180	170
360	350

Centrally locked high quality steel cabinets for storage of tools and small components. Mounted under workbenches with brackets (included). One model available with wheels as an independent tool trolley. Six size alternatives. Steel cabinets are semiconductive epoxy powder coated in grey paint, RAL 7045. Central locking. Full width drawer handle in anodised aluminium. Smooth and quiet telescopic ball-race runners and clear opening of 405 mm. Load capacity 35 kg/drawer. Drawer size 500 x 406 mm.

#### Suitability

- For TP/TPH/SAP benches of 700 mm depth and over, all cabinets are suitable. Mounting brackets for these benches are included.
- For WB benches we recommend cabinets ML 01 and ML 02. Cover MLS needed for mounting, ordered separately.

#### Dividers MLX 1 ESD

Includes 7 fixed compartments. Height 50 mm. Conductive polystyrene.

#### Dividers MLX 2/50

Includes a frame, 3 longitudinal dividers and 15 internal dividers. Height 38 mm. Galvanised steel.

#### Dividers MLX 2/100

Includes a frame, 3 longitudinal dividers and 15 internal dividers. Height 68 mm. Galvanised steel.

#### Cover MLS

Needed for mounting cabinets to WB benches.



	Code	Includes drawers Outer height mm	Outer dims D x L x H mm
	ML 01 ESD	1 x 140	580 x 453 x 142
	ML 02 ESD	1 x 60 2 x 120	580 x 490 x 351
	ML 03 ESD	1 x 60 2 x 120 1 x 180	580 x 490 x 532
	ML 04 ESD	1 x 60 2 x 120 1 x 180 + top, handle and 4 castors	580 x 490 x 670
	ML 05 ESD*	1 x 120 1 x 360	580 x 490 x 532
	ML 06 ESD*	1 x 60 3 x 120 1 x 180 + plinth, H = 110 mm	580 x 490 x 762

\*) To order

# light steel cabinets LMC







These updated steel cabinets are an ideal way of providing individual secure storage for your staff. Drawers mounted on telescopic ball race slides. Four new cabinet sizes, including one drawer/cupboard combination. These cabinets suit any Treston workbench. The cabinet frames are semiconductive epoxy powder coated steel; drawer fronts are semiconductive coated composite board with aluminium handles. Colour light grey, RAL 7035. Load capacity is 15 kg per drawer. Mount on benches with brackets (included). Outer height of the drawer 100 mm, inner dims D x L x H: 425 x 302 x 70 mm

Suitable for

- WS/WB/TP/TPH workbenches
- SAP/CTR/WTR trolleys

## Cover LMCK2

Needed for mounting cabinets to WB benches.

	Code	Includes drawers Outer height mm	Outer dims D x L x H mm
	LMC 01 ESD	1 x 100	460 x 370 x 140
	LMC 02 ESD	2 x 100	460 x 370 x 345
	LMC 04 ESD	4 x 100	460 x 370 x 455
	LMC 04D ESD	1 x 100 + cupboard, height 300 mm, open to right	460 x 370 x 455

In the picture:

Bench WB 815 ESD  
Cabinet LMC 02 ESD  
Cover LMCK2



In the picture:

Trolley SAP 710 ESD  
Steel cabinet LMC 02 ESD  
Lower shelf AT 710 ESD



In the picture:

Trolley CTR 705 ESD  
Steel cabinet LMC 02 ESD



# lighting units



Lighting is an essential part of workstation ergonomics, as well designed lighting aids industrial safety, comfort and productivity. Treston lighting units are specifically designed to fulfil this function. Particular applications need both sidelights and overlight. This system provides the best possible illumination. Quick, flicker-free electronic light ignition and vibrationless operation. Light output unaffected by fluctuations in voltage. Suitable for use with moving machinery giving asymmetric lighting with minimal shadow. (Flicker free tubes ensure that rotating objects will not appear to be stationary, a common optical effect when standard fluorescent tubes are used.)

## Overlight OL 254

Silver grey anodized aluminium frame with a matte anti-dazzle screen. Angle continuously adjustable. Quick, flicker-free electronic light ignition. With own switch and 3 m cable. The lighting units are isolated from the workbench. Mount on support bracket for WB/WS/TPH/HDB/HDBL-benches with fittings supplied.

Length: 1200 mm.

Enclosure class: IP 20.

2 x fluorescent tubes: 54W

## Overlight with dimmer OL 254 D

A dimmer and 3 m cable are included.

Length: 1200 mm.

Enclosure class: IP 20.

2 x fluorescent tubes: 54W

## Sidelight SL 224

Construction as OL 254. Mount on vertical aluminium profile of WS/WB/HDB/HDBL benches with fittings supplied. Connectors and screws as standard.

Length: 590 mm

Enclosure class: IP 20

2 x fluorescent tubes: 24W

Accessories: Mounting kit SL-HKC required for use with TPH benches; ordered separately.

## Graph of light intensity

Light intensity (lux) is tested on a horizontal worktop using the OL 254. The diagram right shows the results. Worktop size is 700 x 1500 mm, height of light unit above worktop is 1000 mm.



OL 254



SL 224

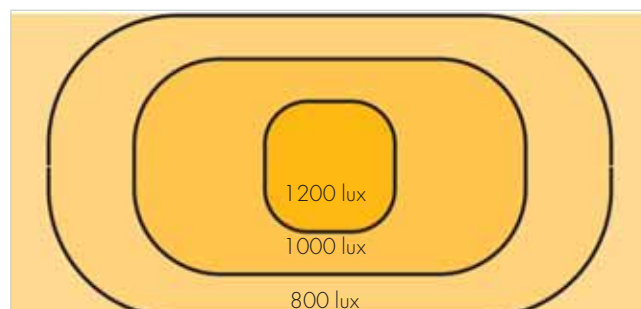

# computer accessories

These accessories are practical and space saving.

## Keyboard shelf NT 500 ESD

A pull-out keyboard shelf with integral wrist support and mouse pad to mount underneath the bench worktop. Outer dims D x L x H 250 x 500 x 110 mm.

Suitable for

- WB/WS/TP/TPH- workbenches
- SAP/WTR- trolleys

## PC stand CPU

An adjustable holder for either vertical or horizontal CPU, to mount underneath the bench worktop. Suitable for WB/WS/TP/TPH benches and SAP/CTR/WTR trolleys.

Width	Height
130...240 mm	395...500 mm/
340...460 mm	180...285 mm

Suitable for

- WB/WS/TP/TPH- workbenches
- SAP/CTR/WTR- trolleys

## LCD bracket MH

A flat panel monitor bracket/plate to suit monitors with mounting holes at 75/100mm centres.

Suitable for

- WS/WB benches
- TPH benches, connector HKC-MH/MA needed for mounting, ordered separately.
- WTR trolley

## LCD swivel arm MA

- max load 5 kgs

A flat panel monitor arm and plate to suit monitors with mounting holes at 75/100 mm centres. The arm is double articulated, turns through a radius of 180° and will extend between 95-425 mm from the upright.

Suitable for

- WS/WB benches
- TPH benches, connector HKC-MH/MA needed for mounting, ordered separately.
- WTR trolley

## LCD swivel arm MA 2

- max load 10 kgs

A flat panel monitor bolstered arm and plate to suit monitors with mounting holes at 75/100 mm centres. The arm is double articulated, turns through a radius of 180° and will extend between 95-425 mm from the upright.

Suitable for

- WS/WB benches
- TPH benches, connector HKC-MA2 needed for mounting, ordered separately.
- WTR trolley

# other accessories

## Bottle holder CH

Practical holder for bottle or cup. Made of black polypropylene. Inside diameter 80 mm. Outside dimensions: L x W x H: 110 x 105 x 120 mm

Suitable for :

- AL2X-, WS-, WTR profile

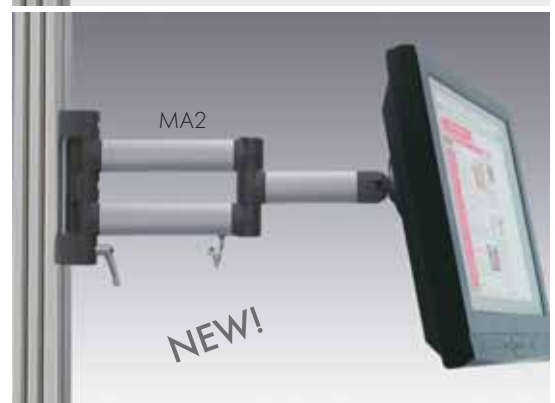
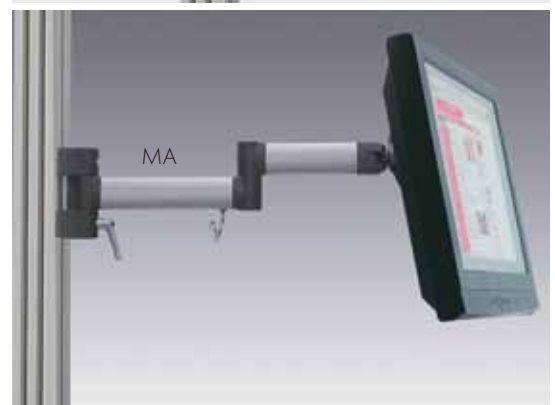

# universal trolley WTR



A good quality, versatile trolley, PC-station, measuring station or mobile storage. Modern industrial design.

## 1. Universal trolley WTR 140 ESD

Standard trolley has 3 shelves (TS 605), size 650 x 530 mm. Height adjustment of shelves by allen-key. The vertical profiles are of aluminium. Frames are of semiconductive epoxy powder coated steel: light grey RAL 7035. The shelves are 26 mm ESD-laminate. Four conductive swivel castors Ø 100 mm of which two are braked. Load capacity 150 kg. Outer dimensions D x W x H: 650 x 650 x 1415 mm.

## 2. Extra shelf TS 605 ESD

Shelf of 26 mm ESD-laminate, size 650 x 530 mm. Load capacity 50 kg.

## 3. Adjustable shelf TAS 605 ESD

Continuous adjustment for depth, height and angle. 26 mm ESD-laminate, size 650 x 530 mm. Lipped front edge. Load capacity 50 kg.

## 4. Bin profile BP 50 ESD

Aluminium profile for TRESTON stacking and picking bins. Length 525 mm.

## 5. Cable channel WJK 40

May be fitted with a choice of components, ordered separately. All meet with CE requirements. 3 m cable is included. Profile length 470 mm.

### COMPONENTS

- E1 Double socket (max. 5 pcs/1 cable)
- E2 Switch
- E3 Automatic fuse 10 A
- E4 Automatic fuse/earth leakage switch 10 A/30 mA
- E5 Emergency-stop-switch
- E6 Data connector/shielded for Cat.6 cable
- E7 Data connector/without screen for Cat.5
- E8 Pneumatic, quick coupling 3/8"

Light steel cabinets, page 13  
Keyboard shelf, page 15



# industrial trolley IT

A versatile trolley that has been designed for use in light assembly, test and repair areas.

## 1. Industrial trolley IT 170 ESD

Frames with perforated profiles are of semiconductive epoxy powder coated steel in grey (RAL 7045). One perforated panel is included with the trolley, size 200 x 685mm. Four conductive castors Ø 125 mm, two with brakes. Load capacity 150 kg. Overall dimensions D x W x H: 625 x 777 x 1725 mm.

## 2. Steel shelf ISS

Adjustment for height, depth and angle 0...30°. With front retaining lip. Of semiconductive epoxy powder coated steel in grey (RAL 7045). Load capacity 40 kg. Two sizes.

Code	Dimensions
ISS 407	400 x 680 mm
ISS 607	600 x 680 mm

## 3. Perforated panel HPP 73

Perforated panel of epoxy powder coated steel in light grey. 9 mm perforations at 38 mm centres. Size 686 x 750 mm.

## 4. Bin rail BP 70 ESD

Height adjustable aluminium bin rail, to hold Treston stacking and picking bins. Length 685 mm.

## 5. Cupboard unit HCU 73

Constructed of epoxy powder coated, perforated steel in light grey: 9 mm perforations at 38 mm centres. Lock, steel shelf and connectors as standard. Dimensions D x W x H: 310 x 687 x 700 mm.



Combination in the picture:

- 1 x trolley IT 170 ESD
- 2 x shelf ISS 407 ESD
- 1 x shelf ISS 607 ESD

Combination in the picture:

- 1 x trolley IT 170 ESD
- 1 x perforated panel HPP 73
- 1 x bin profile BP 70 ESD

Combination in the picture:

- 1 x trolley IT 170 ESD
- 1 x shelf ISS 607 ESD
- 1 x cupboard unit HCU 73

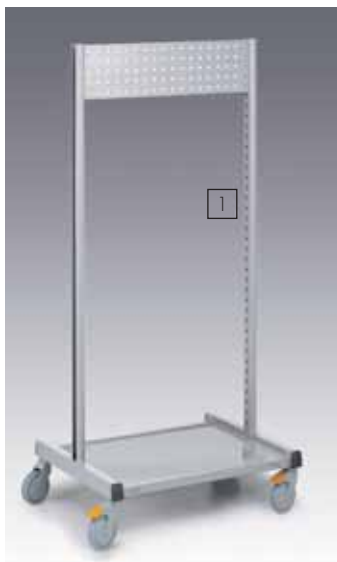

# adjustable trolleys TRTA



These ESD protected trolleys provide a flexible solution to product movement within the production area, extra shelves can be added as required. Height of all shelves can be adjusted by allen-key. Frames are of semiconductive epoxy powder coated steel in grey (RAL 7045). Shelves are of 12 mm ESD-laminate with semiconductive steel edging. Four conductive swivel castors Ø 125 mm of which 2 are braked.

## 2-shelf trolleys

Shelf adjustments between 200...770 mm. Load capacities: max. 150 kg/trolley and max. 50 kg/shelf.

Code	Shelf size	Outer measurements
	D x W mm	D x W x H mm
TRTA 4082 ESD	430 x 800	535 x 900 x 1015
TRTA 4102 ESD	430 x 1000	535 x 1100 x 1015
TRTA 5082 ESD	530 x 800	635 x 900 x 1015
TRTA 5102 ESD	530 x 1000	635 x 1100 x 1015

## 4-shelf trolleys

Shelf adjustments between 215...1340 mm. Load capacities: max. 300 kg/trolley and max. 50 kg/shelf.

Code	Shelf size	Outer measurements
	D x W mm	D x W x H mm
TRTA 4104 ESD	430 x 1000	535 x 1100 x 1535
TRTA 5104 ESD	530 x 1000	635 x 1100 x 1535

## Extra shelf TRHA

Shelves are of 12 mm ESD-laminate with semiconductive steel edging. Load capacity 50 kg.

Code	Shelf size
	D x W mm
TRHA 408 ESD	430 x 800
TRHA 410 ESD	430 x 1000
TRHA 508 ESD	530 x 800
TRHA 510 ESD	530 x 1000

## End mesh panels NET 2 ESD

The mesh panels can be installed at the ends of the trolley or on the sides. An angle bracket is set on the edge of the upper and lower shelf and the mesh is screwed into place. The 4-shelf trolley can hold 2 mesh panels on top of each other. Steel mesh is epoxy coated in grey. Size 364 x 604 mm. One set includes 2 mesh panels.

## Document holder DSA4 ESD

Document stand A4. Semiconductive epoxy powder coated steel. Includes two magnets.



# reel holder trolley RRT



This modern, adjustable trolley is designed for the safe transport and storage of SMD reels. One trolley combination offers storage for up to 360 SMD spoils.

## 1. Reel holder trolley RRT ESD

The basic unit consists of 3 supports for reel racks and a lower shelf. The perforated lower rail prevents dust build-up. The reel supports and lower shelf can be adjusted by allen-key. Frames, reel supports and lower shelf are of semiconductive epoxy powder coated steel in grey (RAL 7045). 4 conductive swivel castors Ø 125 mm with brakes. Load capacities: 50 kg/support and 200 kg/trolley. Overall dimensions D x L x H: 540 x 1100 x 1785 mm. Reel holders are ordered separately.

## 2. Reel rack RR ESD

Designed for use with SMD spoils of 7", 13" and 15" size. The rack includes 15 fixed double compartments of 60 mm width. Frame is of semiconductive epoxy powder coated steel wire in grey (RAL 7035). Full length, antistatic label holder. Load capacity 50 kg. Racks are specifically designed for standard metric shelving. Dimensions D x L x H: 426 x 960 x 254 mm.

## 3. Document holder DSA4 ESD

Document stand A4. Semiconductive epoxy powder coated steel. Includes two magnets.

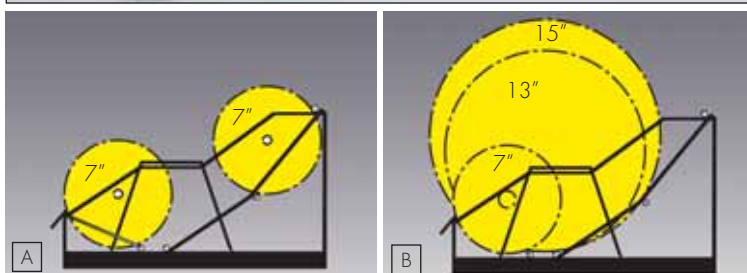

In picture A: Side view of spoils and reel racks  
The capacity of one rack is 30 fixed compartments for 7" spoils of 60 mm width...

In picture B: Side view of spoils and reel racks  
... and 15 fixed compartments for 13" and 15" spoils of 60 mm width.

# upholstered chairs X

Design Yrjö Kukkapuro & Reijo Raatesalmi



NEW!

Arm rests available separately



## Chair X 30G ESD

A gas lift controls height adjustment. The back rest is mechanically adjusted. Tilt of seat and angle and height of back rest mechanically adjusted. The padding is fireproof foam with a high quality wool fabric. As an option the chairs have a wear resistant and washable polyurethane surface. Conductive swivelling twin castors, which are braked when unloaded, are standard.

- ESD-textile: grey 95% polyacrylic, 5% polyester with steel fibres
- seat height: 425...565 mm
- seat: 445 x 455 mm
- back rest: 370 x 275 mm
- arm rests optional



## High chair X 35G ESD

Construction as X 30G ESD, but the high chairs have a foot ring and conductive floor glides to improve work safety.

- ESD-textile: grey 95% polyacrylic, 5% polyester with steel fibres
- seat height: 510...770 mm
- seat: 445 x 455 mm
- back rest: 370 x 275 mm
- arm rests optional



## Syncro chair X 40BL ESD

A high quality Syncro tilt-mechanism allowing the angle of the seat and back to be adjusted separately with just one lever and your body weight. Tilt tension can be adjusted. A gas lift controls height adjustment. The back rest, tilt of seat and angle and height of back rest mechanically adjusted. With adjustable head rest. Conductive swivelling twin castors, which are braked when unloaded, are standard.

- ESD-textile: black 94% wool, 4% polyamide, 2% steel fibre
- seat height: 455...595 mm
- seat: 475x 455 mm
- back rest: 510 x 430 mm
- head rest height: 100 mm
- arm rests optional



## Syncro chair X 40 G ESD

Construction as X40 ESD.

- ESD-textile: grey 95% polyacrylic, 5% polyester with steel fibres

## Arm rest AR ESD

The arm rests have a 80 mm height range and 50mm depth range. With the correct settings the armrests take the weight off your shoulders. The armrests can be set either forwards or backwards. By reversing the armrests you can sit closer to the workbench.

## Properties of conductive TRESTON chairs

The ESD chairs are to the international standard IEC 61340-5-1.

The upholstery is electrically conductive. Contact between upholstery and frame is conductive. Frame is conductive. Earth via conductive castors. The use of dissipative matting or flooring is recommended. NOTE: To ensure good contact clean the castors regularly.

# industrial chairs X PU

Design Yrjö Kukkapuro & Reijo Raatesalmi

NEW!



Arm rests available separately



## Footrest JT 2 ESD

The footrest will help provide workers with an ergonomically correct sitting position and improve working performance. The special feature of this rest is the fluted foot exercise roller which refreshes through light massage while working. The surface is corrugated to prevent slip, made of black conductive polystyrene PS. Dims: 500 x 370 x 100 mm



## Chair X 20 PU ESD

A gas lift controls height adjustment. The back rest is mechanically adjusted. Tilt of seat and angle and height of back rest mechanically adjusted. The black polyurethane seat and back has a wear resistant and washable surface. The chairs are very comfortable to sit in and offer excellent lumbar support. The grooves are a final touch. They act as lines giving the chairs a new strong visual effect and lightness. Chair base anodized aluminium in grey and black. Conductive swivelling twin castors, which are braked when unloaded, are standard.

- seat height: 410...560 mm
- seat: 370 x 425 mm
- back rest: 350 x 265 mm
- arm rests optional



## High chair X 25 PU ESD

Construction as X 20 PU ESD, but the high chairs have a foot ring and conductive floor glides to improve work safety.

- seat height: 500...760 mm
- seat: 370 x 425 mm
- back rest: 350 x 265 mm
- arm rests optional



## Arm rest AR ESD

The arm rests have a 80 mm height range and 50 mm depth range. With the correct settings the armrests take the weight off your shoulders.

## Stool X 10 PU

A black polyurethane seat Ø 350 mm. Conductive swivelling twin castors, which are braked when unloaded, are standard. Seat height 370...510 mm.



## Saddle stool KJ 200 ESD

Grey conductive upholstery. The saddle seat with adjustable tilt provides comfort and an ergonomically correct sitting position.

- seat height: 540... 800 mm.

## Properties of conductive TRESTON chairs

The ESD chairs are to the international standard IEC 61340-5-1.

The upholstery is electrically conductive. Contact between upholstery and frame is conductive. Frame is conductive. Earth via conductive castors. The use of dissipative matting or flooring is recommended. NOTE: To ensure good contact clean the castors regularly.

# industrial office screen system



The compact and modern Treston Industrial Office Screen system with panel and accessory options can be used almost anywhere; from production facilities to offices. Screens are made of ESD materials. Create a uniform, stylish look with Treston screens throughout your company!

## Screen panels

An anodized aluminium frame holds panels made of conductive blue or grey fabric panelling or perforated panel. The fabrics are antistatic. The perforated steel panel is epoxy powder coated in light grey RAL 7035, 9 mm perforations at 38 mm centres. Divider screen panels can be used individually, in straight lines, or at right angles to form enclosed spaces. There are four different panel sizes.

## Legs

- TLEG 400 is suitable for all low panels, and high fabric panels. Complete assembly's height: 1275 - 1315 mm (low panels) 2030 - 2070 mm (high panels)
- TLEG 600 is suitable for all high panels, fabric and steel. Adjustable feet are provided for fine levelling. Complete assembly's height: 2070 - 2080 mm.
- CLEG- corner leg set for all panels. Can be used with two panels to create a 90 deg corner.
- LLEG 250 is suitable for all low panels, and high fabric panels. Complete assembly's height: 1275 - 1315 mm (low panels) 2030 - 2070 mm (high panels)
- One screen panel will need a panel and two legs, which are ordered separately.
- Straight line assemblies require two legs for the first panel and one leg for each additional panel.





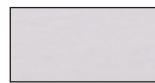



FB  
Colour: blue, RAL 5010

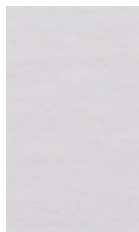

FG  
Colour: grey RAL 7035



S  
Colour: grey RAL 7035. Perforated screen: steel

Screen panels				Suitability of legs (ordered separately, 1 pcs per pack)			
			Outer dims L x H mm				
Blue fabric	Grey fabrics	Perf. panel		T-leg 400	T-leg 600	L-leg 250	Corner leg set
P 0712 FB ESD	P 0712 FG ESD	P 0712 S	750 x 1245	TLEG400	—	LLEG250	CLEG
P 0720 FB ESD	P 0720 FG ESD	P 0720 S	750 x 2000	TLEG400*	TLEG600	LLEG250*	CLEG
P 1012 FB ESD	P 1012 FG ESD	P 1012 S	1050 x 1245	TLEG400	—	LLEG250	CLEG
P 1020 FB ESD	P 1020 FG ESD	P 1020 S	1050 x 2000	TLEG400*	TLEG600	LLEG250*	CLEG

\*) We recommend this leg for the low panels but it can be mounted to high fabric panels and all corner layouts.



Noise from production areas or loud talking from neighbouring workstations are often disturbing factors. One way of reducing the noise level is to divide workspaces from each other and/or separate them from production areas. This can be easily done with Treston screens. An individual workstation aids concentration and improves accuracy. TRESTON ESD screens and their materials are to international standards. (VTT Research centre Finland).

### Bin rail PBP

Aluminium rail for TRESTON stacking bins 1015, 1520, 1525 and 1930. Load capacity 10 kg. Aluminium profile/semiconductive epoxy powder coated steel. Max 3 profiles/one side.

### Steel shelf PSS

Steel semiconductive epoxy powder coated shelf. The shelf can sit on the brackets as normal or hang from the brackets to provide end stops. Load capacity 10 kg. Max. 3 shelves/one side.

### Cable channel PJK

May be fitted with a choice of components, ordered separately. All meet with CE requirements. 3 m cable is included. Supplied wired and ready for use.

#### COMPONENTS

- E1 Double socket
- E2 Switch
- E3 Automatic fuse 10 A
- E4 Aut./earth leakage switch 10 A/30 mA
- E5 Emergency-stop-switch
- E6 Data connector/shielded for Cat.6 cable
- E7 Data connector for Cat.5
- E8 Pneumatic, quick coupling 3/8"



Bin profile	profile
PBP 70 ESD	700 mm
PBP 100 ESD	1000 mm

Steel shelf	D x L
PSS 70 ESD	170 x 710 mm
PSS 100 ESD	170 x 1010 mm

Cable channel	profile
PJK 70	640 mm
PJK 100	940 mm

# shelf cabinets



## Shelf cabinet HK 48 ESD

Shelf cabinets are made of high-quality 1 mm profiled steel. A strong welded sheet steel body and sturdy double-skinned doors provide safe and secure storage. The doors are fitted with double point locking. The shelves can be adjusted on 61 mm centres. Cabinets of semiconductive epoxy powder coated steel in 2 tone grey: frame light grey RAL

35 and doors grey RAL 7045. Standard fittings: Abloy cabinet lock with two keys, sturdy double leaf-doors, 4 pcs adjustable feet, 4 shelves, of which one is fixed at the lock height. Dimensions D x W x H: 423 x 800 x 2005 mm. Load capacity 80 kg/shelf and 300 kg/cabinet.

## Extra shelf H 48 ESD

Size 400 x 735 mm

## Perforated panel RLHK 48

Size 735 x 600 mm

## Shelf cabinets HK 100/180 ESD

Designed for use in light storage. This cabinet comes in an individual carton with all necessary fittings and instructions. Steel cabinets are epoxy powder coated in light grey. The shelves can be adjusted on 50 mm centres. Standard fittings: Locking bar system, steel double doors, 1 or 3 shelves and cabinet base. Max. load 50 kg/shelf and 200 kg/HK 180. 150 kg/HK 100 ESD.

Code	Shelves	Dimensions D x W x H mm
HK 100 ESD	1	460 x 915 x 1015
HK 180 ESD	3	460 x 915 x 1830

## Extra shelf H 49 K ESD

Size 450 x 880 mm

## Perforated panel RLHK 49

Size 880 x 550 mm



# small parts shelving, earthing box, ESD-mats



## 1. Small parts storage shelving PH

An ESD protected, effective storage system. Small parts shelving with accessories are of semiconductive epoxy powder coated steel in light grey RAL 7035. Earth via protective 1 megohm resistor. Height 2020 mm. Accessories: Extra shelf, dividing panel, side panel and back panel

## 2. Extension unit PH-L

Product	Code	Shelf dims D x W mm	Load capacity/ one shelf
Shelving unit	PH 410 ESD	400 x 1000	150 kg
	PH 510 ESD	500 x 1000	200 kg
	PH 610 ESD	600 x 1000	200 kg
Extension unit	PH 410L ESD	400 x 1000	150 kg
	PH 510L ESD	500 x 1000	200 kg
	PH 610L ESD	600 x 1000	200 kg
Shelf	H 410 ESD	400 x 1000	150 kg
	H 510 ESD	500 x 1000	200 kg
	H 610 ESD	600 x 1000	200 kg



## 3. PCB-container PK 1 ESD

Printed circuit board container has been designed for single and double Eurocard and many other smaller size PCBs. Asymmetrical dividers are adjustable in 2,5 mm and 5 mm steps. The dimensions are to EUR standards. Size fits storage box 10-36L-4ESD, see page 31. Outer dimensions: 285 x 475 x 210 mm. Inner dimensions: 235 x 423 x 161 mm. Accessories: dividers PKV 1 ESD

## 4. Component rack EPL 12 ESD

Rack with three fixed shelves. Of semiconductive epoxy powder coated steel in light grey (RAL 7035). Size fits swivel arms AKV and CKV, see pages 7 and 11. Outer d x w x h: 200 x 455 x 290 mm. Component rack holds: 12 stacking bins 1015-4ESD or 12 picking bins 30-1L-4ESD or 6 picking bins 30-2L-4ESD or 6 picking bins 30-23L-4ESD. Bins ordered separately.

## 5. Adjustable wrist strap R 2216

High quality wrist band for the safe discharge of static from the operator. Wrist strap set includes wrist band and coiled cord. Adjustable, elastic conductive fabric wrist strap. Earth lead with 1 megohm resistor, length 1,8 m. Includes 7 mm press stud for connection to wrist strap and 10 mm press stud for connection to earthing point.

## 6. Metal wrist strap R 2206

Adjustable metal wrist strap. Construction as wrist straps R 2216.

## 7. Earthing box J 6603

Mounts securely to the underside of a workbench or shelf 3 x 10 mm studs for safely connecting a worker's wrist strap Fitted with 3 x 1 megaohm 1/2 watt safety resistor Includes a 3 metre earthing cord to keep the earth bonding point and workers safely grounded at all times

## 8 Earthing cable MK 3040

Earthing cable, 5 m, for the bench and flooring mats with 10 mm press stud (male), 1 megohm.

## 9. Press stud PN 3034

For the bench and flooring mats. 10mm/female



## 10. ESD-flooring LM 9500

Dissipative, hard wearing vinyl flooring requiring permanent on site installation. Supplied by the metre or on rolls. Accessories: Press stud and earthing cable. Roll size: 1,5 x 25 m. Colour: grey. Surface resistivity: 100K ohm

## 11 Bench top ESD-mats PM 157

Resistant to heat, solder flux, most chemicals and solvents. The ESDmats are to IEC 61340-5-1 standards. Abraded non slip underside. Does not contain PVC. Supplied by the metre or on rolls. Accessories: Press stud and earthing cable. Roll size: 1,22 x 10,00 m (12,20 m<sup>2</sup>). Colour: platinum grey. Resistance surface to ground: 7,5 x 10<sup>5</sup>...10<sup>7</sup> ohm.

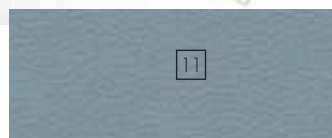

# small parts storage cabinets



Cabinets, which combine a stylish industrial design with practical accessories to provide flexible and efficient ESD protected small parts storage. They can be wall hung or mounted on space-saving turntables or stood on the worktop. Available in two sizes with heights 290 and 550 mm.

## Construction

The design combines the use of a strong, semiconductive polypropylene frame and galvanised steel shelves in such a way that small drawers of semiconductive polystyrene sit securely within the framework. Supplied with labels and connector for earth lead. Details of the small parts drawers can be found on page 28. Accessories: cross dividers of semiconductive polystyrene.

## 291 ESD

- frame size D x W x H: 180 x 310 x 290 mm
- with 24 drawers, type L-61-4ESD
- accessories: cross divider V-1-4ESD

## 294 ESD

- frame size D x W x H: 180 x 310 x 290 mm
- with 12 drawers, type L-64-4ESD
- accessories: cross divider V-4-4ESD

## 551 ESD

- frame size D x W x H: 180 x 310 x 550 mm
- with 48 drawers, type L-61-4ESD
- accessories: cross divider V-1-4ESD

## 554 ESD

- frame size D x W x H: 180 x 310 x 550 mm
- with 24 drawers, type L-64-4ESD
- accessories: cross divider V-4-4ESD

## Bench top spacemiser PTP-5 ESD

This unit consists of a combination ball bearing base/baseplate and will hold 2 small parts storage cabinets 291/294 ESD or 551/554 ESD which are ordered separately. Earthing cable is included. Load capacity 50 kg.

Complete assembly's dimensions D x W x H:  
310 x 360 x 300 mm (291 ESD/294 ESD)  
310 x 360 x 560 mm (551 ESD/554 ESD)



# spacemiser, stands and trolley



Perfect for the location, storage and identification of thousands of small components.

## Spacemiser 12-550 ESD

This unit consists of a combination ball bearing base/ baseplate and dividing trays and top plate and will hold 12 small parts storage cabinets 551/554 ESD in three layers. Each layer contains four cabinets which are ordered separately. This unit includes ball bearing base, dividing trays and a baseplate. Load capacity 400 kg. Earth via protective 1 megohm resistor. Complete assembly's dimensions D x W x H: 500 x 500 x 1730 mm

## Single stand BS-550L ESD

This assembly holds 4 small parts storage cabinets 551/ 554 ESD which are ordered separately. Free standing frame of semiconductive epoxy powder coated steel in light grey RAL 7035. 3 aluminium rails are included. Load capacity 50 kg. Overall dims D x W x H: 420 x 760 x 1585 mm.

## Double stand BS-550T ESD

This assembly holds 8 small parts storage cabinets 551/ 554 ESD which are ordered separately. Construction as single stand. Load capacity 100 kg. Overall dimensions D x W x H: 600 x 760 x 1585 mm.

## Trolley BT-550 ESD

This assembly holds 8 small parts storage cabinets 551/ 554 ESD which are ordered separately. Construction as double stand. With bottom shelf of 12 mm ESD-laminate. Four castors Ø 100 mm which two are conductive and two braked. Load capacity 150 kg. Overall dimensions D x W x H: 600 x 760 x 1700 mm.

12-550 ESD +  
12 small parts storage cabinets



BS-550L ESD + 4 small parts  
storage cabinets



BS-550T ESD + 8 small  
parts storage cabinets



BT-550 ESD +  
8 small parts storage cabinets

# storage cabinets, turntables



Storage cabinets are stackable vertically and may be wall hung or mounted on turntable assemblies. Available in two sizes with depths 300 and 400 mm.



## Construction

The cabinet has a strong, steel frame, galvanised steel shelves, semiconductive bins and labels with protective shields (not conductive). Supplied with connector for earth lead. Details of the drawers can be found on page 30. Accessories: cross dividers of semiconductive polypropylene.

## 0830 ESD

- frame size D x W x H: 300 x 400 x 395 mm
- with 8 drawers, type: 3020-4ESD
- accessories: cross divider D-20-4ESD

## 1630 ESD

- frame size D x W x H: 300 x 400 x 395 mm
- with 16 drawers, type: 3010-4ESD
- accessories: cross divider D-10-4ESD

## 0840 ESD

- frame size D x W x H: 400 x 400 x 395 mm
- with 8 drawers, type: 4020-4ESD
- accessories: cross divider D-20-4ESD

## 1640 ESD

- frame size D x W x H: 400 x 400 x 395 mm
- with 16 drawers, type: 4010-4ESD
- accessories: cross divider D-10-4ESD

## Turntable 16-300 ESD

This unit holds 16 Bin Cabinets 0830/1630 ESD which are ordered separately. This unit includes a ball bearing base and dividing trays. Load capacity 800 kg. Earth via protective 1 megohm resistor. Complete assembly's dimensions D x W x H: 700 x 700 x 1680 mm.

## Turntable 16-400 ESD

This unit holds 16 Bin Cabinets 0840/1640 ESD which are ordered separately. This unit includes a ball bearing base and dividing trays. Load capacity 800 kg. Earth via protective 1 megohm resistor. Complete assembly's dimensions D x W x H: 800 x 800 x 1680 mm



16-300 ESD +  
16 storage cabinets

# high density cabinets



4840 ESD



2440 ESD

ESD protected high density cabinets for the electronics industry – providing static or mobile storage. Robust construction. Load capacity 240 kg.

## Construction

Designed as freestanding units. There is a choice of 2 different bin combinations. Each cabinet includes a grey semiconductive epoxy enamelled steel frame (RAL 7035), galvanised steel shelves, semiconductive bins and labels with protective shields (not conductive). Adjustable feet are provided for fine levelling. Load capacity for the cabinet is 240 kg/ 30 kg per shelf. Dividers are available separately. Details of the storage bins can be found on page 30. Accessories: cross dividers and castors.

## 2440 ESD

- frame size D x W x H: 410 x 605 x 870 mm
- with 24 drawers, type: 4020-4ESD
- accessories: cross divider D-20-4ESD

## 4840 ESD

- frame size D x W x H: 410 x 605 x 870 mm
- with 48 drawers, type: 4010-4ESD
- accessories: cross divider D-10-4ESD

## Castor set PS-LH ESD

4 conductive castors Ø 100 mm, 2 with brakes. Load capacity of cabinet with castors is 150 kg.



2440 ESD +  
PS-LH ESD

# conductive bins ESD

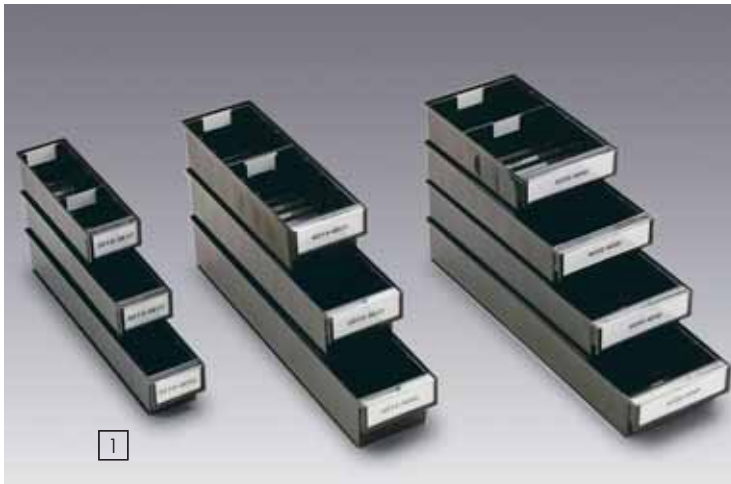

1



Dividers V-60

2



3

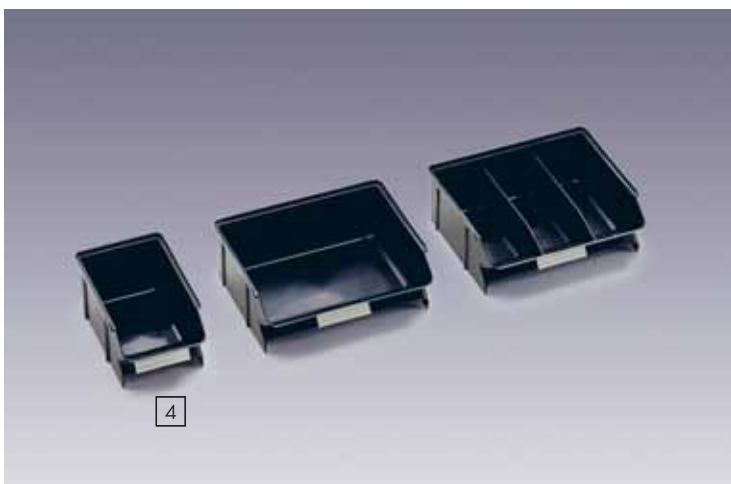

4

## 1. Storage bins

Storage Bins with corrugated base are suitable for all standard shelves with a depth 300, 400, 500 and 600 mm. The corrugated base design eases the picking of the smallest of items. These bins stack securely, as do bins of different depths when the width is the same. Material: semiconductive polypropylene. Full width label with protective shield is included with the bin. Label holders simply lift off when necessary. Shield is not conductive. Accessories: cross dividers.

Code	Outer dims D x W x H mm	Dividers (ordered separately)
3010-4ESD	300 x 92 x 82	D-10-4ESD
3020-4ESD	300 x 186 x 82	D-20-4ESD
4010-4ESD	400 x 92 x 82	D-10-4ESD
4015-4ESD	400 x 132 x 100	D-15-4ESD
4020-4ESD	400 x 186 x 82	D-20-4ESD
5010-4ESD	500 x 92 x 82	D-10-4ESD
5015-4ESD	500 x 132 x 100	D-15-4ESD
5020-4ESD	500 x 186 x 82	D-20-4ESD
6015-4ESD	600 x 132 x 100	D-15-4ESD
6020-4ESD	600 x 186 x 82	D-20-4ESD

## 2. Storage bin with smooth base

Storage bins, with smooth sides and bases, are effective space savers. Bin 1562 is specifically designed for storing IC dispensing tubes. Material: semiconductive polystyrene. Label with protective shield is included with the bin. Shields are not conductive. Accessories: cross or lengthway dividers.

Code	Outer dims D x W x H mm	Dividers (ordered separately)
1562-4ESD	625 x 140 x 90	V-15-4ESD

## 3. Small parts drawers

Available in two sizes. Accessories: cross divider.

Code	Outer dims D x W x H mm	Dividers (ordered separately)
L-61-4ESD	170 x 69 x 40	V-1-4ESD
L-64-4ESD	170 x 92 x 62	V-4-4ESD

## 4. Picking bins

Picking bins are intended for repeated and rapid picking. Material: Semiconductive polystyrene (PS).

Code	Outer dims D x W x H mm	
30-1L-4ESD	160 x 99 x 70	
30-2L-4ESD	160 x 198 x 70	
30-23L-4ESD	160 x 198 x 70	2 fixed length dividers

### Semiconductive polypropylene = PP

- surface resistivity  $10^3 \dots 10^6$  ohm
- volume resistivity  $10^3 \dots 10^6$  ohm
- temperature tolerance  $-20 \dots +70^\circ\text{C}$

### Semiconductive polystyrene = PS

- surface resistivity  $10^3 \dots 10^6$  ohm
- volume resistivity  $10^3 \dots 10^6$  ohm
- temperature tolerance  $-40 \dots +65^\circ\text{C}$

# conductive bins ESD



5

## 5. Stacking bins

For use on louvred panel and rail systems. Their open front design gives good access. Corrugated base eases the picking of the smallest of items. Material: Semiconductive polypropylene (PP). Accessories: Cross dividers are of semiconductive epoxy powder coated steel. Label with shield, shields are not conductive.

Code	Outer dims D x W x Hmm	Dividers (ordered separately)	Labels
1015-4ESD	165 x 105 x 75	—	E-10
1520-4ESD	192 x 149 x 105	—	E-15
1525-4ESD	250 x 149 x 130	V-14	E-15
1930-4ESD	300 x 186 x 156	V-19	E-20
1940-4ESD	400 x 186 x 156	V-19	E-20



6

## 6. Large stacking bins

Material: semiconductive polypropylene. Made only to order. Please ask for details. Accessories: Label with shield, shields are not conductive.

Code	Outer dims D x W x Hmm	Labels) (ordered separately)
1950-4ESD*	510 x 186 x 182	E-20
3050-4ESD*	500 x 310 x 182	E-20



7

## 7. Large stacking bins

Material: semiconductive polypropylene. Made only to order. Please ask for details.

Code	Outer dims D x W x Hmm
1949-4ESD*	490 x 185 x 250
3149-4ESD*	490 x 310 x 250

## 8. Storage boxes

Straight sided storage boxes of 18 and 36 litre capacity are used for internal and external transport systems. These have integral handles and stack securely together. Material: Semiconductive polystyrene (PS).

Code	Outer dims D x W x Hmm
10-18L-4ESD	535 x 323 x 150
10-36L-4ESD	508 x 323 x 280



8

### Semiconductive polypropylene = PP

- surface resistivity  $10^3 \dots 10^6$  ohm
- volume resistivity  $10^3 \dots 10^6$  ohm
- temperature tolerance -20...+70°C

### Semiconductive polystyrene = PS

- surface resistivity  $10^3 \dots 10^6$  ohm
- volume resistivity  $10^3 \dots 10^6$  ohm
- temperature tolerance -40...+ 65°C

\*) Made only to order. Please ask for details.

# stacking bin stands, trolley



## 1. Single stand BS-160LA ESD

Free standing frame of semiconductive epoxy powder coated steel in light grey RAL 7035. 8 adjustable, double sided bin rails, length 740 mm. Stacking bins are ordered separately. Load capacity 120 kg. Overall size D x W x H: 420 x 820 x 1585 mm

## 2. Double stand BS-160TA ESD

Free standing frame of semiconductive epoxy powder coated steel in light grey RAL 7035. 8 adjustable bin rails, length 740 mm. Stacking bins are ordered separately. Load capacity 240 kg. Overall size D x W x H: 600 x 820 x 1585 mm

## 3. Trolley BT-170A ESD

As double stand. Bottom shelf of 12 mm ESD-laminate. 4 castors Ø 100 mm which two are conductive and two braked. Load capacities: trolley 150 kg. Overall size D x W x H: 600 x 820 x 1700 mm.

## 4. Stacking bins

Suitability of stacking bins for stands: Bins can be hung on both sides of the double sided rails. Stacking bins, see page 31.

One rail will hold either

- 7 pcs 1015-4ESD
- 5 pcs 1520-4ESD
- 5 pcs 1525-4ESD
- 4 pcs 1930-4ESD.



**TRESTON**<sup>®</sup>  
RELIABLE INDUSTRIAL FURNITURE

Treston reserves the right to amend specifications without prior notification.